

MEMBRANE INSTALLATION

1

Remove 2 Philips screws from the bottom of the unit.

2

Slowly lift the cover up vertically.

3

Be careful not to pull the wires attached to the cover. Rotate the cover and place it in front of the system.

4

Disconnect tubing connected to membrane housing cap. Remove the caps using the included wrench, turning counterclockwise.

5

Lubricate each membrane's O-ring with food-grade silicone before inserting them into the housing.

6

Make sure each membrane is fully seated in the housing.

7

Reinstall both membrane housing caps and reconnect tubing.

8

Center the membrane housings and wiring. Then reinstall cover and 2 Philips screws.

MOUNTING THE SYSTEM

FILTER INSTALLATION

9

Match the filter label color to head label color and align the filter key.

10

Slide the filter up into the head vertically and then rotate the filter to the right. Repeat for all 3 filters.

11

Mount RO System with a minimum 6 inches of clearance between the ground and bottom of the filter. Use mounting guide on page 23 of manual for hole alignment.

LEAK DETECTOR CONNECTION

12

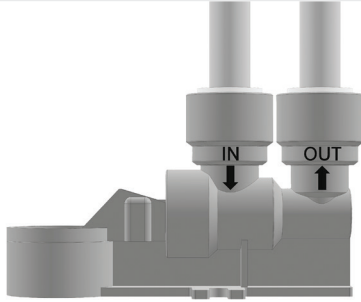

Caution: This must be plumbed prior to the RO System.

- A)** For feed, connect 3/8" white tubing from water supply to the "IN" port of the leak detector.
- B)** Remove wrapper from the leak detector pad and place it inside the detector.
- C)** Close the cap of the detector to allow water to flow through the valve.

TUBING CONNECTION

13

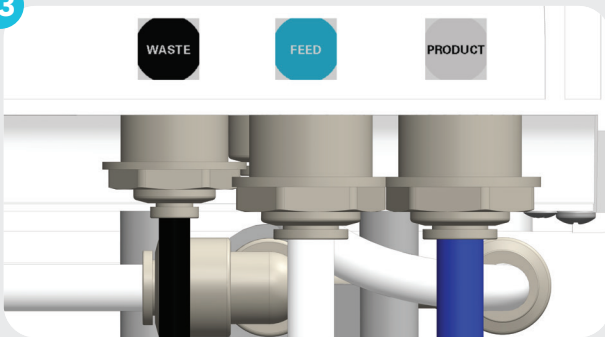

- A)** For waste water connection, connect the 1/4" black tubing to the "WASTE" port and to the drain. Ensure the tubing is unrestricted and has no back pressure.
- B)** For water supply, connect the 3/8" white tubing from the "OUT" port of the leak detector to the "FEED" port of the RO System.
- C)** For product connection, connect the 3/8" blue tubing to the "PRODUCT" port and to the storage tank (not included).