

Reverse Osmosis User's Manual

M1 – Series



M1-12240 Pictured

This Page Intentionally
Left Blank

TABLE OF CONTENTS

INTRODUCTION.....	4
SAFETY	4
FEEDWATER AND OPERATIONS SPECIFICATIONS.....	5
REJECTION, RECOVERY AND FLOW RATES.....	5
SYSTEM REQUIREMENTS AND OPERATION GUIDELINES.....	6
MEMBRANE ELEMENTS.....	8
SYSTEM IDENTIFICATION	9
SYSTEMS PART LIST	10
PRODUCT SPECIFICATIONS	11
SYSTEM PURGING	12
INITIAL START-UP	12
OPERATING DOs AND DON'Ts	13
OPERATION AND MAINTENANCE	13
MEMBRANE REMOVAL AND REPLACEMENT	15
FLUSHING THE SYSTEM.....	17
PREPARING UNIT FOR STORAGE OR SHIPMENT	17
REVERSE OSMOSIS TROUBLESHOOTING	18
TEMPERATURE CORRECTION FACTORS FOR MEMBRANE.....	20
OPERATING LOG.....	22
FLOW DIAGRAMS	23
ELECTRICAL SCHEMATICS	28
SYSTEM WARRANTY	36

INTRODUCTION

Your M1-Series system is a durable piece of equipment which, with proper care, will last for many years. This User's Manual outlines installation, operation, maintenance, and troubleshooting details vital to the sustained performance of your system.

The test results which are included with this User's Manual indicate your system's permeate (product) and concentrate (waste) test results.

If your system is altered at the site of operation or if the feed water conditions change, please contact your local dealer or distributor to determine the proper recovery for your application.

NOTE: IN ORDER TO MAINTAIN THE MANUFACTURER'S WARRANTY, AN OPERATING LOG MUST BE MAINTAINED AND COPIES WILL NEED TO BE SENT TO YOUR LOCAL DEALER OR DISTRIBUTOR FOR REVIEW.

NOTE: PRIOR TO OPERATING OR SERVICING THE REVERSE OSMOSIS SYSTEM, THIS USER'S MANUAL MUST BE READ AND FULLY UNDERSTOOD. KEEP THIS AND OTHER ASSOCIATED INFORMATION FOR FUTURE REFERENCE AND FOR NEW OPERATORS OR QUALIFIED PERSONNEL NEAR THE SYSTEM.

SAFETY

The Safety section of this User's Manual outlines the various safety headings used throughout this manual's text and are enhanced and defined below:

NOTE: INDICATES STATEMENTS THAT PROVIDE FURTHER INFORMATION AND CLARIFICATION.



CAUTION: INDICATES STATEMENTS THAT ARE USED TO IDENTIFY CONDITIONS OR PRACTICES THAT COULD RESULT IN EQUIPMENT OR OTHER PROPERTY DAMAGE.



WARNING: INDICATES STATEMENTS THAT ARE USED TO IDENTIFY CONDITIONS OR PRACTICES THAT COULD RESULT IN INJURY OR LOSS OF LIFE. FAILURE TO FOLLOW WARNINGS COULD RESULT IN SERIOUS INJURY OR EVEN DEATH.



DO NOT UNDER ANY CIRCUMSTANCE; REMOVE ANY CAUTION, WARNING, OR OTHER DESCRIPTIVE LABELS FROM THE SYSTEM.

FEED WATER AND OPERATION SPECIFICATIONS

Nothing has a greater effect on a reverse osmosis system than the feed water quality.

NOTE: IT IS VERY IMPORTANT TO MEET THE MINIMUM FEED WATER REQUIREMENTS. FAILURE TO DO SO WILL CAUSE THE MEMBRANES TO FOUL AND VOID THE MANUFACTURER'S WARRANTY.

Operating Limits

Maximum Feed Temperature °F (°C)	85 (29)	Maximum Free Chlorine ppm	0
Minimum Feed Temperature °F (°C)	40 (4.4)	Maximum TDS ppm	2,000
Maximum Ambient Temperature °F (°C)	120 (48.9)	Maximum Hardness gpg	0
Minimum Ambient Temperature °F (°C)	40 (4.4)	Maximum pH (Continuous)	11
Maximum Feed Pressure psi (bar)	85 (5.9)	Minimum pH (Continuous)	5
Minimum Feed Pressure psi (bar)	45 (3.1)	Maximum pH (Cleaning 30 Min.)	12
Maximum Operating Pressure psi (bar)	200 (13.8)	Minimum pH (Cleaning 30 Min.)	2
Maximum SDI Rating SDI	<3	Maximum Turbidity NTU	1

Test Parameters: 550 TDS Filtered (5 Micron), De-Chlorinated, Municipal Feed Water, 65 psi (4.5 bar) Feed Pressure, 100 psi (6.89 bar) Operating Pressure, 77 Degrees F (25 Degrees C), Recovery as stated, 7.0 pH. Data taken after 60 minutes of operation.

Low temperatures and high feed water TDS levels will significantly affect the system's production capabilities. Computer projections should be run for individual applications which do not meet or exceed minimum and maximum operating limits.

Scale prevention measures must be taken to prolong membrane life.

NOTE: HIGHER FEED TDS AND/OR LOWER TEMPERATURES WILL REDUCE THE SYSTEM'S PRODUCTION.

REJECTION, RECOVERY AND FLOW RATES

M1-Series reverse osmosis systems are designed to produce permeate water at the capacities indicated in the "design basis section" on page 22 of this manual. For example, the M1-12240 produces 25 gallons per minute of permeate water at the listed operating test conditions.

The amount of total dissolved solids (TDS) rejected by the membrane is expressed as a percentage. For example, a 99% rejection rate means that 99% of total dissolved solids do not pass through the membrane. To calculate the % rejection, use the following formula:

$$\% \text{ Rejection} = [(\text{Feed TDS} - \text{Product TDS}) / \text{Feed TDS}] \times 100$$

Example:

$$99\% = [(550-5.5)/550] \times 100$$

NOTE: ALL TDS FIGURES MUST BE EXPRESSED IN THE SAME UNITS, TYPICALLY PARTS PER MILLION (PPM) OR MILLIGRAMS PER LITER (MG/L).

M1-Series reverse osmosis systems are designed to reject up to 99% NaCl, unless computer projections have been provided or stated otherwise.

The amount of permeate water recovered for use is expressed as a percentage. To calculate % recovery, use the following formula:

$$\% \text{ Recovery} = (\text{Product Water Flow Rate} / \text{Feed Water Flow Rate}) \times 100$$

Example:

$$66\% = (25/38) \times 100$$

$$\% \text{ Rejection} = [(\text{Feed TDS} - \text{Product TDS}) / \text{Feed TDS}] \times 100$$

Example:

$$99\% = [(550-5.5)/550] \times 100$$

NOTE: ALL FLOW RATES MUST BE EXPRESSED IN THE SAME UNITS.

SYSTEM REQUIREMENTS AND OPERATION GUIDELINES

PLUMBING

The membranes and high pressure pumps used on M1-Series systems require a continuous flow of water with a minimum feed pressure of 45 psi, not to exceed 90°F.

FEED WATER CONNECTION

1. Locate the 1-1/2" FNPT Solenoid Valve feed water inlet. (Figure 1A, Page 17)
2. Attach the inlet piping to the 1-1/2" FNPT Solenoid Valve feed water inlet.
3. Be certain that all of the dissolved solids within the feed water are soluble at the concentrations attained in the system.

PERMEATE (PRODUCT WATER) CONNECTION

Locate the 1" or 1-1/2" connection labeled permeate and attach to storage tank. Ensure that the permeate water can flow freely with no backpressure. Backpressure can cause irreversible damage to the membrane elements. The 1" or 1-1/2" permeate line can be run to the holding tank with PVC fittings, or other FDA approved materials. This is so the material being used does not dissolve into the permeate water.



CAUTION THE pH OF THE REVERSE OSMOSIS PERMEATE WATER WILL TYPICALLY BE 1-2 pH UNITS LOWER THAN THE FEED WATER pH. A LOW pH CAN BE VERY AGGRESSIVE TO SOME PLUMBING MATERIALS SUCH AS COPPER PIPING.

CONCENTRATE (WASTE WATER) CONNECTION

Locate the 1" or 1-1/2" connection labeled concentrate and attach to a drain. Run the concentrate line to an open drain in a free and unrestricted manner (no backpressure). It is advised that an air-break be used on the concentrate line to prevent siphoning of water from the pressure vessels when the system is in standby.



CAUTION: ANY RESTRICTIONS OR BLOCKAGE IN THE DRAIN LINE CAN CAUSE BACKPRESSURE, WHICH WILL INCREASE THE SYSTEM'S OPERATING PRESSURE. THIS CAN RESULT IN DAMAGE TO THE SYSTEM'S MEMBRANES AND COMPONENTS.

ELECTRICAL

The motor used on the M1-Series systems are pump and motor combination. The motor is available in 220/460 Volt, 50/60 Hertz, 3 phase.

Ensure that the electrical circuit supplying the system is compatible with the requirements of the specific M1 model you are installing.

NOTE: IT'S RECOMMENDED THAT A LICENSED ELECTRICIAN WIRE YOUR SYSTEM IN ACCORDANCE WITH LOCAL AND NATIONAL ELECTRICAL CODES (NEC).



WARNING: TO REDUCE THE RISK OF ELECTRICAL SHOCK, THE INCOMING POWER SUPPLY MUST INCLUDE A PROTECTIVE EARTH GROUND.

M1-Series systems are typically controlled with a liquid level switch in a storage tank. The liquid level switch turns the system on when the water level in the tank drops, and off when the tank is full. Liquid level switches can be obtained by your local dealer or distributor. If a liquid level switch is to be used, install it at this time.

PRE-FILTRATION

M1-Series systems are supplied with a 5 micron sediment bag filter. Change the bag filter once a month or when a 10-15 psi differential exists between the two pre-filter gauges. Ask your local dealer or distributor about Pre-Filtration systems, if required.

NOTE: THE SYSTEM MUST BE OPERATED USING FILTERED FEED WATER ONLY.

PUMP

The pump used on the M1-Series systems is of the multi-stage centrifugal stainless steel type.

Follow these guidelines to ensure proper operation of the pump:

- The pump must **NEVER** be run dry. Operating the pump without sufficient feed water will damage the pump.
- **ALWAYS** feed the pump with filtered water. The pump is susceptible to damage from sediment and debris.
- If any damage occurs to your system's pump a re-build kit may be available. Contact your local dealer or distributor and inform them of your system's model and pump size.

MOUNTING

The free standing system should be bolted down in compliance with local regulation standards or securely fastened.

MEMBRANE ELEMENTS

M1-Series reverse osmosis systems come pre-loaded with Thin Film Composite (TFC) HF5 High Flow Extra Low Energy membranes, unless otherwise specified. General membrane element performance characteristics here:

HF5

- Membrane Type: Polyamide Thin-Film Composite
- pH Range, Short Term Cleaning (30 Min.): 1 – 13
- Maximum Operating Temperature: 113°F (45°C)
- Maximum Feed Silt Density Index: 5
- Maximum Operating Pressure: 400 psi (27.58 bar)
- Chlorine Tolerance: 0 ppm
- pH Range, Continuous Operation*: 2 – 11

* Maximum temperature for continuous operations above pH10 is 95° F (35°c)

Product Specifications						
Part Number	Description	Applied Pressure psi (bar)	Permeate Flow Rate psi (gpd)	Applied Pressure psi (bar)	Permeate Flow Rate gpd (m3/d)	Nominal Salt Rejection (%)
200392	HF5 – 4014	80 (5.52)	600 (2.27)	100 (6.89)	720 (3.72)	98.5
200393	HF5 – 4021	80 (5.52)	1000 (3.79)	100 (6.89)	1200 (4.54)	98.5
200394	HF5 – 4040	80 (5.52)	2500 (9.46)	100 (6.89)	3000 (11.36)	98.5

Test Parameters: 550 TDS Filtered (5 Micron), De-Chlorinated, Municipal Feed Water, 77 Degrees F, 15% Permeate Recovery, 6.5 - 7.0 pH Range, at the Specified Operating Pressure. Data Taken After 30 Minutes of Operation. Maximum Pressure drop for each element is 13 psi. Minimum salt rejection is 96%. Permeate flow for individual elements may vary +/- 20%.

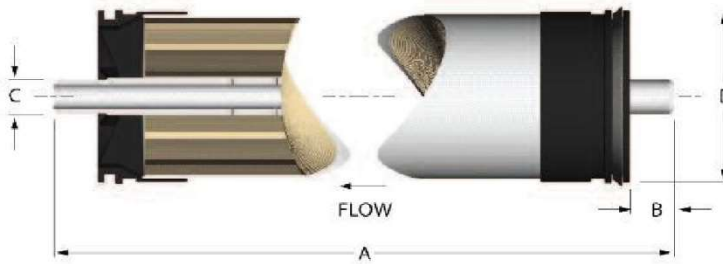

Dimensions inch (mm):				
Description	A	B	C	D
HF5 – 4014	14 (355.6)	1.1 (27.94)	0.75 (19.05)	3.95 (100.3)
HF5 – 4021	21 (533.4)	1.1 (27.94)	0.75 (19.05)	3.95 (100.3)
HF5 – 4040	40 (1016.0)	1.1 (27.94)	0.75 (19.05)	3.95 (100.3)

Under certain conditions, the presence of free chlorine and other oxidizing agents will cause premature membrane failure. Since oxidation damage is not covered under warranty, the manufacturer recommends removing residual free chlorine by pretreatment prior to membrane exposure. Wet tested membrane elements must be kept sealed and moist when in storage. Drying out may occur and damage the membrane permanently. Prevent elements from freezing or being exposed to direct sunlight. Wet tested elements are vacuum sealed in a polyethylene bag containing 1.0% sodium meta-bisulfite and then packaged in a cardboard box. Discard the permeate for the first twenty-four hours of operation. The permeate flow (product water flow) varies with feed water temperature. For membrane warranty information, please contact the manufacturer.

The manufacturer believes the information and data contained herein to be accurate and useful. The information and data are offered in good faith, but without guarantee, as conditions and methods of use of products are beyond the manufacturer's control. The manufacturer assumes no liability for results obtained or damages incurred through the application of the presented information and data. It is the user's responsibility to determine the appropriateness of these products for the user's specific end uses.

M1 – SERIES
SYSTEM IDENTIFICATION

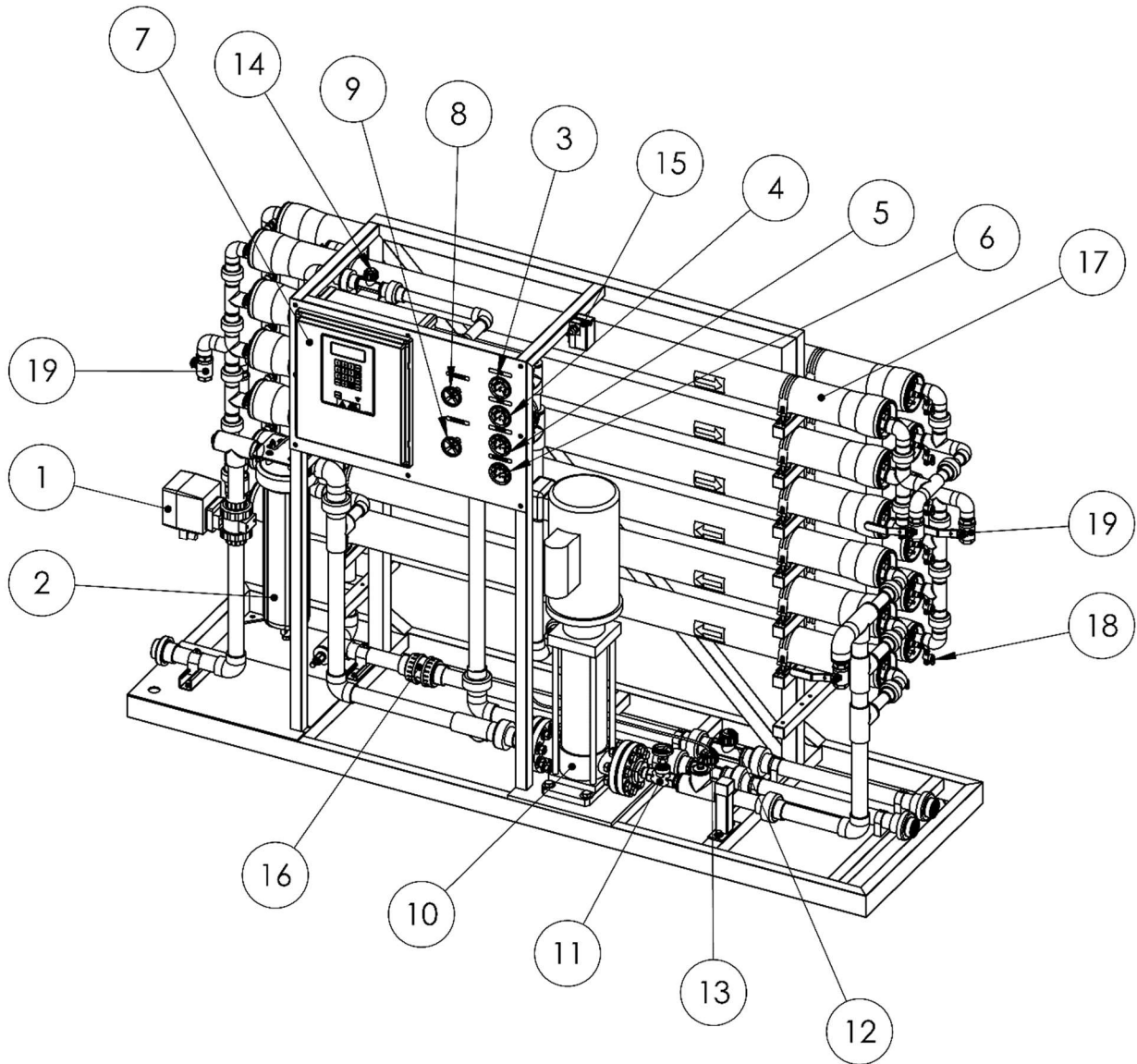

FIGURE 1

SYSTEMS PART LIST

1. **MOTORIZED BALL VALVE** – TURNS ON/OFF FEED WATER
2. **5 MICRON SEDIMENT** – REMOVES PARTICULATES
3. **PRESSURE GAUGE** – MEASURES FEED PRESSURE
4. **PRESSURE GAUGE** – MEASURES PRESSURE AFTER FILTERS
5. **PRESSURE GAUGE** – MEASURES PUMP PRESSURE
6. **PRESSURE GAUGE** – MEASURES CONCENTRATE PRESSURE
7. **COMPUTER CONTROL** – CONTROLS RO SYSTEM FUNCTIONS
8. **RECYCLE VALVE** – RECYCLES CONCENTRATE BACK TO FEED (IF APPLICABLE)
9. **CONCENTRATE VALVE**– CONTROLS FLOW OF CONCENTRATE (WASTE) WATER TO THE DRAIN
10. **RO PUMP AND MOTOR** – PRESSURIZES RO SYSTEM
11. **THROTTLE VALVE** – CONTROLS FLOW OF PUMP
12. **FLOW METER / SENSOR** – MEASURES FLOW OF PERMEATE WATER
13. **FLOW METER / SENSOR** – MEASURES FLOW OF CONCENTRATE (WASTE) WATER
14. **FLOW METER / SENSOR** – MEASURES FLOW OF CONCENTRATE RECYCLE WATER
15. **PRESSURE SWITCH** – TURNS OFF RO PUMP WHEN FEED PRESSURE FALLS BELOW 15PSI
16. **PERMEATE CHECK VALVE** – PROTECTS MEMBRANE ELEMENTS FROM BACKPRESSURE
17. **PRESSURE VESSELS** – HOUSES MEMBRANE ELEMENTS
18. **PERMEATE SAMPLE VALVE**- MEASURES THE QUALITY OF EACH MEMBRANE
19. **CLEANING PORT VALVE**- PROVIDES ACCESS TO CLEAN THE MEMBRANES

PRODUCT SPECIFICATIONS

Models	M1-4240	M1-6240	M1-8240	M1-10240	M1-12240
Design					
Configuration	Single Pass	Single Pass	Single Pass	Single Pass	Single Pass
Feed Water Source***	TDS<2,000 ppm	TDS<2,000 ppm	TDS<2,000 ppm	TDS<2,000 ppm	TDS<2,000 ppm
Standard Recovery Rate	50-75%	50-75%	50-75%	50-75%	60-75%
Rejection and Flow Rates					
Nominal Salt Rejection %	99	99	99	99	99
Permeate Flow* gpm (lpm)	8.3 (31.6)	12.5 (47.3)	16.7 (63.1)	20.8 (78.9)	25.0 (94.6)
Minimum Feed Flow gpm (lpm)	11.3 (42.9)	15.5 (58.7)	22.7 (85.8)	26.8 (101.6)	31.0 (117.4)
Maximum Feed Flow gpm (lpm)	48 (181.7)	48 (181.7)	48 (181.7)	48 (181.7)	48 (181.7)
Minimum Concentrate Flow gpm (lpm) with Recycle Based on 75% Recovery	3.00 (11.36)	4.17 (15.79)	5.56 (21.04)	6.95 (26.31)	8.33 (31.53)
Connections					
Feed inch	1.5" FNPT	1.5" FNPT	1.5" FNPT	1.5" FNPT	1.5" FNPT
Permeate inch	1" FNPT	1" FNPT	1" FNPT	1.5" FNPT	1.5" FNPT
Concentrate inch	1" FNPT	1" FNPT	1" FNPT	1.5" FNPT	1.5" FNPT
CPI inch	1" FNPT	1" FNPT	1" FNPT	1" FNPT	1" FNPT
Membranes					
Membrane(s) Per Vessel	2	2	2	2	2
Membrane Quantity	8	12	16	20	24
Membrane Size	4040	4040	4040	4040	4040
Vessels					
Vessel Array	1:1:1:1	2:2:1:1	3:3:2	3:3:2:2	3:3:2:2:2
Vessel Quantity	4	6	8	10	12
Pumps					
Pump Type	Multi-Stage	Multi-Stage	Multi-Stage	Multi-Stage	Multi-Stage
Motor HP (kw)	3	3	5	7.5	7.5
RPM @ 60 Hz	3450	3450	3450	3450	3450
RPM @ 50 Hz	VFD at 60Hz	VFD at 60Hz	VFD at 60Hz	VFD at 60Hz	VFD at 60Hz
Electrical					
Standard Voltage	220V, 60Hz, 1Ph, 14.6A	220V, 60Hz, 1Ph, 14.6A	220V, 60Hz, 3Ph, 13.6A	220V, 60Hz, 3Ph, 19.2A	220V, 60Hz, 3Ph, 19.2A
Voltage Options	220V, 50Hz, 1Ph, 17.4A 220V, 50Hz, 3Ph, 10.6A 220V, 60Hz, 3 Ph, 9A 460V, 60Hz, 3 Ph, 5A	220V, 50Hz, 1Ph, 17.4A 220V, 50Hz, 3Ph, 10.6A 220V, 60Hz, 3 Ph, 9A 460V, 60Hz, 3 Ph, 5A	220V, 50Hz, 3Ph, 16.1A 460V, 60Hz, 3 Ph, 7A	220V, 50Hz, 3Ph, 22.9A 460V, 60Hz, 3 Ph, 9.7A	220V, 50Hz, 3Ph, 22.9A 460V, 60Hz, 3 Ph, 9.7A
Systems Dimensions **					
L x W x H inch (cm)	31 x 100 x 64 (78 x 254 x 162)	31 x 100 x 64 (78 x 254 x 162)	31 x 100 x 64 (78 x 254 x 162)	31 x 100 x 64 (78 x 254 x 162)	31 x 100 x 64 (78 x 254 x 162)
Weight lb. (kg)	1060 (481)	1150 (520)	1260 (572)	1350 (612)	1450 (658)

* Product flow and recovery rates are based on equipment test parameters.

†† Standard for all 50Hz Systems

** Does not include operating space requirements.

*** Treatment ability of the RO system is dependent on feed water quality. Performance projections must be run for each installation.



WARNING: NEVER EXCEED THE SYSTEM'S MAXIMUM PRESSURE RATING

SYSTEM PURGING

Carefully inspect your system before initial start-up. Check that all plumbing and electrical connections are not loose or have not come undone during shipment. A User's Manual and Test Results will accompany your M1-Series reverse osmosis system.

NOTE: LEAVE THE POWER TO THE SYSTEM OFF FOR THIS PROCEDURE.

1. Redirect permeate water to the drain for this procedure.
2. Fully open the concentrate valve (Counter Clockwise). (Figure 1, Page. 10)
3. Fully close the recycle valve (Clockwise) (If Applicable). (Figure 1, Page. 10)
4. Fully open the throttle valve (Counter Clockwise). (Figure 1, Page. 10)
5. Press and hold the reset button on the S-150 controller for three seconds to activate the solenoid bypass feature.

Note: Purging procedure with a Rotrol II controller.

1. Redirect permeate water to the drain for this procedure.
2. Fully open the concentrate valve (Counter Clockwise). (Figure 1, Page. 10)
3. Fully close the recycle valve (Clockwise) (If Applicable). (Figure 1, Page. 10)
4. Fully open the throttle valve (Counter Clockwise). (Figure 1, Page. 10)
5. Press the FUNCTION key once.
6. Press number 2.
7. Press the ENTER key to initiate a manual flush.

The unit will flush with feed water for 5 minutes. Once the time expires STANDBY will be displayed on the screen.

INITIAL START-UP

1. Keep the permeate water line to drain for this procedure.
2. Fully open the concentrate valve (Counter Clockwise). (Figure 1, Page. 10)
3. Fully close the recycle valve (Clockwise)(If Applicable). (Figure 1, Page. 10)
4. Adjust the throttle valve at 50% open (Counter Clockwise). (Figure 1, Page. 10)
5. Turn the RO system on and adjust the concentrate (waste) valve, recycle valve (If Applicable), and the throttle valve to the designed flow and pressure. (Figure 1, Page. 10)
6. Inspect the system for leaks.
7. Allow the system to run 30 minutes to flush the preservative solution from the system.
8. After 30 minutes, shut down the system.
9. Re-direct the permeate water back to the tank and then turn the system back on.
10. Record the readings daily for a week; after one week record the readings once a week.

OPERATING DOs AND DON'Ts

DO:

- Change the cartridge filters regularly
- Monitor the system and keep a daily log
- Run the system as much as possible on a continuous basis.
- Adjust the system recovery to the recommended value
- Always feed the pump with filtered water.

DON'T:

- Permit chlorine to enter or be present in the feed water
- Shut down the system for extended periods
- Close the throttle valve completely
- Operate the system with insufficient feed flow
- Operate the pump dry

OPERATION AND MAINTENANCE

The reverse osmosis process causes the concentration of impurities. The impurities may precipitate (fall out of solution) when their concentration reaches saturation levels.

NOTE: PRECIPITATION CAN SCALE OR FOUL MEMBRANES AND MUST BE PREVENTED.

Check your feed water chemistry and pre-treat the water and/or reduce the system's recovery as required. If necessary, consult with your local dealer or distributor.

PRE-FILTER PRESSURE GAUGES

Pre-filter gauges measure the feed water pressure when it enters and exits the pre-filter. A pressure differential of 10 - 15 psi or more on the two pressure gauges indicates that the pre-filters require servicing.

PUMP PRESSURE AND CONCENTRATE PRESSURE GAUGES

Pump and concentrate gauges measure the pressure of water exiting the multistage pump and the pressure of concentrate water as it exits the pressure vessel array. Comparison of the pump output and concentrate pressures allows for the establishment of a baseline pressure differential. If the pressure differential increases over time from this baseline, it would be an indication that the reverse osmosis membranes need to be inspected.

PERMEATE (PRODUCT) FLOW INDICATOR AND CONCENTRATE (WASTE) FLOW INDICATOR

These digital sensors indicate the flow rates of the permeate and concentrate water. The measurements, when added together, also indicate the feed water flow rate or total flow rate if the recycle valve is not being used. If the recycle valve is being used, add the flow rates for all three flow meters (permeate, concentrate, and recycle) to obtain the total feed flow.

LOW PRESSURE SWITCH

The low pressure switch shuts off the system when the feed water pressure drops below 15 PSI, preventing damage to the pump. The system restarts automatically when there is a constant pressure of 35 PSI or more.

PUMP THROTTLE VALVE

The Pump Throttle Valve is installed as a standard feature on the M1-Series reverse osmosis systems. It provides an adjustment for pump pressure. As the feed water temperature decreases, and/or the feed water TDS increases, the system will require a higher operating pressure to produce the specified permeate flow.

ADJUSTING THE THROTTLE VALVE

To decrease the pressure, turn the handle clockwise. To increase the pressure turn the handle counter clockwise. (Figure 2, Page 15)

DECREASE PRESSURE

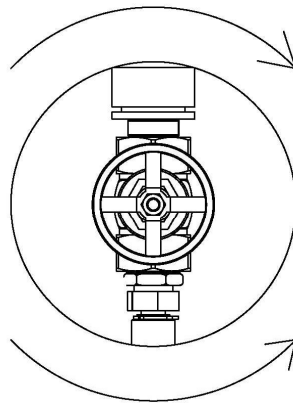

INCREASE PRESSURE

FIGURE 2

MEMBRANE REMOVAL AND REPLACEMENT

Replacing membranes in the pressure vessels is an easy process if you have the proper information and tools at hand. Please refer to the following instructions when removing and replacing membrane elements:



WARNING: ALL PRESSURE GAUGES MUST READ ZERO BEFORE PROCEEDING. BEFORE ATTEMPTING, DISCONNECT THE POWER FROM THE SYSTEM AND BLEED ALL WATER PRESSURE FROM THE SYSTEM.

1. Remove the end plugs from the pressure vessels. This is done by removing the two half-moon retaining disks using a #5 Allen wrench; the end plugs should then freely slide out of the pressure vessel.
2. Remove the replacement membrane element(s) from the shipping box; the membrane(s) should be contained within a plastic oxygen barrier bag.

NOTE: WEAR GLOVES FOR THE FOLLOWING STEPS IN ORDER NOT TO CONTAMINATE THE MEMBRANE.

3. Cut the bag open as close as possible to the seal at one end of the bag, so the bag may be re-used if necessary.
4. Make sure that all parts are clean and free from dirt. Examine the brine seal, and permeate tube for nicks or cuts. Replace the O-rings or brine seal if damaged.
5. Flow directions should be observed for installation of each element into their respective pressure vessels.

REPLACING THE MEMBRANE ELEMENT:



WARNING: THE BRINE SEAL MUST BE IN THE SAME POSITION FOR EACH MEMBRANE ELEMENT HOUSING, SO MARK EACH HOUSING PRIOR TO REMOVING THE MEMBRANE ELEMENTS. THE BRINE SEAL IS A RUBBER SEAL THAT PROTRUDES ON ONE SIDE OF THE MEMBRANE AND IS ALWAYS ON THE FEED SIDE OF THE MEMBRANE ELEMENT.

1. Remove one membrane element at a time from the pressure vessels. Long nose pliers may be necessary to pull the old membrane element out of the membrane element housing.
2. Lubricate the brine seal with a non-petroleum based lubricant, such as Dow Corning® 111.
3. Install membranes with brine seal facing towards the flow arrow.
4. For brine seals that are facing the flow arrow: At a slight angle insert the membrane while slightly rotating the element being careful not to tear or flip the brine seal. A slow twisting motion should be used to insert the membrane element, for every couple of turns pull up ½” to make sure the brine seal doesn’t flip.
5. With a smooth and constant motion, push the membrane element into the housing so the brine seal enters the housing without coming out of the brine seal groove.
6. Re-install the end plugs by gently twisting the end cap while pushing it onto the housing. Ensure that you do not pinch or fatigue any O-rings while re-installing the end plug. Push the end plug on until the outer diameter of the plug is flush with the outer diameter of the pressure vessel.
7. Insert the two half-moon retaining disks until they are fully seated. Subsequently fasten using a #5 Allen wrench.
8. Reconnect any fittings that may have been disconnected when the membrane pressure vessels were disassembled.
9. To Start-Up the system, please refer to the Initial Start-Up section of this manual. (See page 12)



CAUTION: WET MEMBRANES ARE SHIPPED IN A PRESERVATIVE SOLUTION. THE MEMBRANES MUST BE FLUSHED FOR AT LEAST 30 MINUTES TO REMOVE THE PRESERVATIVE FROM THE MEMBRANE. DISCARD ALL OF THE PERMEATE, WHICH IS PRODUCED DURING THE FLUSH PERIOD.

FLUSHING THE SYSTEM

The system should be flushed weekly to remove sediment from the surface of the membranes. To manually flush the system, follow the preceding steps:

1. The system must be operating during the flush procedure.
2. Fully open the concentrate valve. (Figure 1, Page. 10)
3. Allow the system to run for 10 to 20 minutes.
4. After 10 to 20 minutes, close the concentrate valve to its previous setting. Ensure the proper concentrate flow rate is going to the drain.
5. The system is now ready to operate.

PREPARING UNIT FOR STORAGE OR SHIPMENT



PRIOR TO SHIPPING OR STORING YOUR SYSTEM, THE SYSTEM SHOULD BE CLEANED WITH AN APPROPRIATE CLEANER, FLUSHED WITH WATER, AND PROTECTED FROM BIOLOGICAL ATTACK WITH AN APPROPRIATE SOLUTION FOR MEMBRANE ELEMENTS. THE MEMBRANE HOUSING(S) AND PLUMBING LINES OF THE SYSTEM MUST BE COMPLETELY DRAINED. ANY WATER REMAINING IN THE PLUMBING OF A SYSTEM MAY FREEZE, CAUSING SERIOUS DAMAGE.

PREPARING SYSTEM FOR STORAGE:

1. Totally immerse the elements in the membrane housing in a solution of 2% membrane preservative, venting the air outside of the pressure vessels. Use the overflow technique: circulate the Memstor solution in such a way that the remaining air in the system is minimized after the recirculation is completed. After the pressure vessel is filled, the Memstor solution should be allowed to overflow through an opening located higher than the upper end of the highest pressure vessel being filled.
2. Separate the preservation solution from the air outside by closing all valves.
3. Repeat this process at least once a month.

During the shutdown period, the plant must be kept frost-free, or the temperature must not exceed 113°F (45°C).

PREPARING UNIT FOR SHIPMENT:

4. Disconnect the inlet, concentrate, pre-filter, and permeate plumbing.
5. Drain all water from the pre-filter cartridge housings by unscrewing the housings, removing the pre-filter cartridges, and drain the water from the housings.
6. Disconnect the tubing from the connectors on the permeate and concentrate inlets and outlets.
7. Fully open the concentrate valve.
8. Drain the flow meters.
9. Allow the system to drain for a minimum of eight hours or until the opened ports quit dripping.
10. After draining is complete, reconnect all of the plumbing.

REVERSE OSMOSIS TROUBLESHOOTING

SYMPTOMS	POSSIBLE CAUSES	CORRECTIVE ACTION
LOW INLET PRESSURE	Low supply pressure	Increase Inlet Pressure
	Cartridge filters plugged	Change Filters
	Solenoid valve malfunction	Replace Sol. Valve and/or Coil
	Concentrate valve might be damaged	Replace Needle Valve
	Leaks	Fix any visible leaks
LOW PERMEATE FLOW	Cold feed water	See temperature correction sheet
	Low operating pressure	See low inlet pressure
	Defective membrane brine seal/ Membrane installed backwards	Replace brine seal and / or Reposition membranes
	Fouled or Scaled membrane	Clean membranes
	Damaged product tube o-rings	Inspect and/or replace
HIGH PERMEATE FLOW	Damaged or oxidized membrane	Replace membrane
	Exceeding maximum feed water temperature	See temperature correction sheet
	Low operating pressure	Adjust concentrate valve
POOR PERMEATE QUALITY	Damage product tube o-rings	Inspect and/or replace
	Damaged or oxidized membrane	Replace membrane
	Metal Oxide Fouling	Improve pretreatment to remove metals. Clean with Acid Cleaners.
MEMBRANE FOULING	Colloidal Fouling	Optimize pretreatment for colloid removal. Clean with high pH anionic cleaners.
	Scaling (CaSO ₄ , CaSO ₃ , BaSO ₄ , SiO ₂)	Increase acid addition and antiscalant dosage for CaVO ₃ and CaCO ₄ . Reduce recovery. Clean with Acid Cleaners
	Biological Fouling	Shock dosage of Sodium Bi- Sulfate. Continuous feed of Sodium Bi-Sulfate at reduced pH. Chlorination and de-chlorination. Replace cartridge filters.
	Organic Fouling	Activated Carbon or other pretreatment. Clean with high pH cleaner.
	Chlorine Oxidation	Check Chlorine feed equipment and de-chlorination system.
	Abrasion of membrane by Crystalline Material	Improve pretreatment. Check all filters for media leakage.

ABNORMAL PERMEATE FLOW

As time progresses, the efficiency of the membrane will be reduced. In general, the salt rejection does not change significantly until two or three years after installation when operated on properly pretreated feed water. The permeate flow rate will begin to decline slightly after one year of operation, but can be extended with diligent flushing and cleaning of the system. A high pH and/or precipitation of hardness can cause premature loss in rejection.

Permeate flow should be within 20% of the rated production, after correcting the feed water temperatures above or below 77°F. Check your permeate flow meter to determine the permeate flow rate.

NOTE: TO DETERMINE THE TEMPERATURE CORRECTION FACTOR, LOCATE THE TEMPERATURE CORRECTION TABLE IN THIS USER'S MANUAL AND FOLLOW THE DIRECTIONS

TEMPERATURE CORRECTION FACTORS FOR MEMBRANE

Find the temperature correction factor (TCF) from the table below. Divide the rated permeate flow at 77°F by the temperature correction factor. The result is the permeate flow at the desired temperature. (See example on the next page)

Temperature °F (°C)	Temperature Correction Factor	Temperature °F (°C)	Temperature Correction Factor	Temperature °F (°C)	Temperature Correction Factor	Temperature °F (°C)	Temperature Correction Factor	Temperature °F (°C)	Temperature Correction Factor
50.0 (10.0)	1.711	57.2 (14.0)	1.475	64.4 (18.0)	1.276	71.6 (22.0)	1.109	78.8 (26.0)	0.971
50.2 (10.1)	1.705	57.4 (14.1)	1.469	64.6 (18.1)	1.272	71.8 (22.1)	1.105	79.0 (26.1)	0.968
50.4 (10.2)	1.698	57.6 (14.2)	1.464	64.8 (18.2)	1.267	72.0 (22.2)	1.101	79.2 (26.2)	0.965
50.5 (10.3)	1.692	57.7 (14.3)	1.459	64.9 (18.3)	1.262	72.1 (22.3)	1.097	79.3 (26.3)	0.962
50.7 (10.4)	1.686	57.9 (14.4)	1.453	65.1 (18.4)	1.258	72.3 (22.4)	1.093	79.5 (26.4)	0.959
50.9 (10.5)	1.679	58.1 (14.5)	1.448	65.3 (18.5)	1.254	72.5 (22.5)	1.090	79.7 (26.5)	0.957
51.1 (10.6)	1.673	58.3 (14.6)	1.443	65.5 (18.6)	1.249	72.7 (22.6)	1.086	79.9 (26.6)	0.954
51.3 (10.7)	1.667	58.5 (14.7)	1.437	65.7 (18.7)	1.245	72.9 (22.7)	1.082	80.1 (26.7)	0.951
51.4 (10.8)	1.660	58.6 (14.8)	1.432	65.8 (18.8)	1.240	73.0 (22.8)	1.078	80.2 (26.8)	0.948
51.6 (10.9)	1.654	58.8 (14.9)	1.427	66.0 (18.9)	1.236	73.2 (22.9)	1.075	80.4 (26.9)	0.945
51.8 (11.0)	1.648	59.0 (15.0)	1.422	66.2 (19.0)	1.232	73.4 (23.0)	1.071	80.6 (27.0)	0.943
52.0 (11.1)	1.642	59.2 (15.1)	1.417	66.4 (19.1)	1.227	73.6 (23.1)	1.067	80.8 (27.1)	0.940
52.2 (11.2)	1.636	59.4 (15.2)	1.411	66.6 (19.2)	1.223	73.8 (23.2)	1.064	81.0 (27.2)	0.937
52.3 (11.3)	1.630	59.5 (15.3)	1.406	66.7 (19.3)	1.219	73.9 (23.3)	1.060	81.1 (27.3)	0.934
52.5 (11.4)	1.624	59.7 (15.4)	1.401	66.9 (19.4)	1.214	74.1 (23.4)	1.056	81.3 (27.4)	0.932
52.7 (11.5)	1.618	59.9 (15.5)	1.396	67.1 (19.5)	1.210	74.3 (23.5)	1.053	81.5 (27.5)	0.929
52.9 (11.6)	1.611	60.1 (15.6)	1.391	67.3 (19.6)	1.206	74.5 (23.6)	1.049	81.7 (27.6)	0.926
53.1 (11.7)	1.605	60.3 (15.7)	1.386	67.5 (19.7)	1.201	74.7 (23.7)	1.045	81.9 (27.7)	0.924
53.2 (11.8)	1.600	60.4 (15.8)	1.381	67.6 (19.8)	1.197	74.8 (23.8)	1.042	82.0 (27.8)	0.921
53.4 (11.9)	1.594	60.6 (15.9)	1.376	67.8 (19.9)	1.193	75.0 (23.9)	1.038	82.2 (27.9)	0.918
53.6 (12.0)	1.588	60.8 (16.0)	1.371	68.0 (20.0)	1.189	75.2 (24.0)	1.035	82.4 (28.0)	0.915
53.8 (12.1)	1.582	61.0 (16.1)	1.366	68.2 (20.1)	1.185	75.4 (24.1)	1.031	82.6 (28.1)	0.913
54.0 (12.2)	1.576	61.2 (16.2)	1.361	68.4 (20.2)	1.180	75.6 (24.2)	1.028	82.8 (28.2)	0.910
54.1 (12.3)	1.570	61.3 (16.3)	1.356	68.5 (20.3)	1.176	75.7 (24.3)	1.024	82.9 (28.3)	0.908
54.3 (12.4)	1.564	61.5 (16.4)	1.351	68.7 (20.4)	1.172	75.9 (24.4)	1.021	83.1 (28.4)	0.905
54.5 (12.5)	1.558	61.7 (16.5)	1.347	68.9 (20.5)	1.168	76.1 (24.5)	1.017	83.3 (28.5)	0.902
54.7 (12.6)	1.553	61.9 (16.6)	1.342	69.1 (20.6)	1.164	76.3 (24.6)	1.014	83.5 (28.6)	0.900
54.9 (12.7)	1.547	62.1 (16.7)	1.337	69.3 (20.7)	1.160	76.5 (24.7)	1.010	83.7 (28.7)	0.897
55.0 (12.8)	1.541	62.2 (16.8)	1.332	69.4 (20.8)	1.156	76.6 (24.8)	1.007	83.8 (28.8)	0.894
55.2 (12.9)	1.536	62.4 (16.9)	1.327	69.6 (20.9)	1.152	76.8 (24.9)	1.003	84.0 (28.9)	0.892
55.4 (13.0)	1.530	62.6 (17.0)	1.323	69.8 (21.0)	1.148	77.0 (25.0)	1.000	84.2 (29.0)	0.889
55.6 (13.1)	1.524	62.8 (17.1)	1.318	70.0 (21.1)	1.144	77.2 (25.1)	0.997	84.4 (29.1)	0.887
55.8 (13.2)	1.519	63.0 (17.2)	1.313	70.2 (21.2)	1.140	77.4 (25.2)	0.994	84.6 (29.2)	0.884
55.9 (13.3)	1.513	63.1 (17.3)	1.308	70.3 (21.3)	1.136	77.5 (25.3)	0.991	84.7 (29.3)	0.882
56.1 (13.4)	1.508	63.3 (17.4)	1.304	70.5 (21.4)	1.132	77.7 (25.4)	0.988	84.9 (29.4)	0.879
56.3 (13.5)	1.502	63.5 (17.5)	1.299	70.7 (21.5)	1.128	77.9 (25.5)	0.985	85.1 (29.5)	0.877
56.5 (13.6)	1.496	63.7 (17.6)	1.294	70.9 (21.6)	1.124	78.1 (25.6)	0.982	85.3 (29.6)	0.874
56.7 (13.7)	1.491	63.9 (17.7)	1.290	71.1 (21.7)	1.120	78.3 (25.7)	0.979	85.5 (29.7)	0.871
56.8 (13.8)	1.486	64.0 (17.8)	1.285	71.2 (21.8)	1.116	78.4 (25.8)	0.977	85.6 (29.8)	0.869
57.0 (13.9)	1.480	64.2 (17.9)	1.281	71.4 (21.9)	1.112	78.6 (25.9)	0.974	85.8 (29.9)	0.866

*F = (°C x 9/5) + 32

Corrected Flow Rate = (Measured Flow Rate) * [TCF @ Feed Water Temp.]

If a system is rated to produce 5 gpm of permeate water @ 77° F. The same system will produce more water at a higher temperature. It will also produce less water at a lower temperature. Use the temperature correction table to obtain the correct flow.

Example:

5 gpm @ 59° F ($5 \div 1.42 = 3.52$ gpm)

5 gpm @ 77° F ($5 \div 1 = 5$ gpm)

5 gpm @ 84° F ($5 \div 0.89 = 5.62$ gpm)

SERVICE ASSISTANCE

If service assistance is required, please complete the following process:

Contact your local dealer or distributor. Prior to making the call, have the following information available: system installation date, serial number, daily log sheets, current operating parameters (e.g. flow, operating pressures, pH, etc.), and a detailed description of the problem.

OPERATING LOG

Company: _____

Date of Start-Up: _____

Location: _____

Date of Last Cleaning: _____

Week Of: _____

System Serial #: _____

DATE					
TIME					
HOUR OF OPERATION					
FILTER INLET PRESSURE (PSI)					
FILTER OUTLET PRESSURE (PSI)					
CONCENTRATE PRESSURE (PSI)					
PUMP DISCHARGE PRESSURE (PSI)					
FEED FLOW (GPM)					
PERMEATE FLOW (GPM)					
CONCENTRATE FLOW (GPM)					
RECYCLE FLOW (GPM)					
RECOVERY %					
FEED TEMPERATURE					
FEED TDS (PPM)					
PERMEATE TDS (PPM)					
REJECTION %					
FEED PH					
PERMEATE PH					
SCALE INHIBITOR FEED (PPM)					
IRON (mg/L)					
FREE CHLORINE (mg/L)					
HARDNESS (GPG CaCO ₃)					

M1-4240 FLOW DIAGRAM

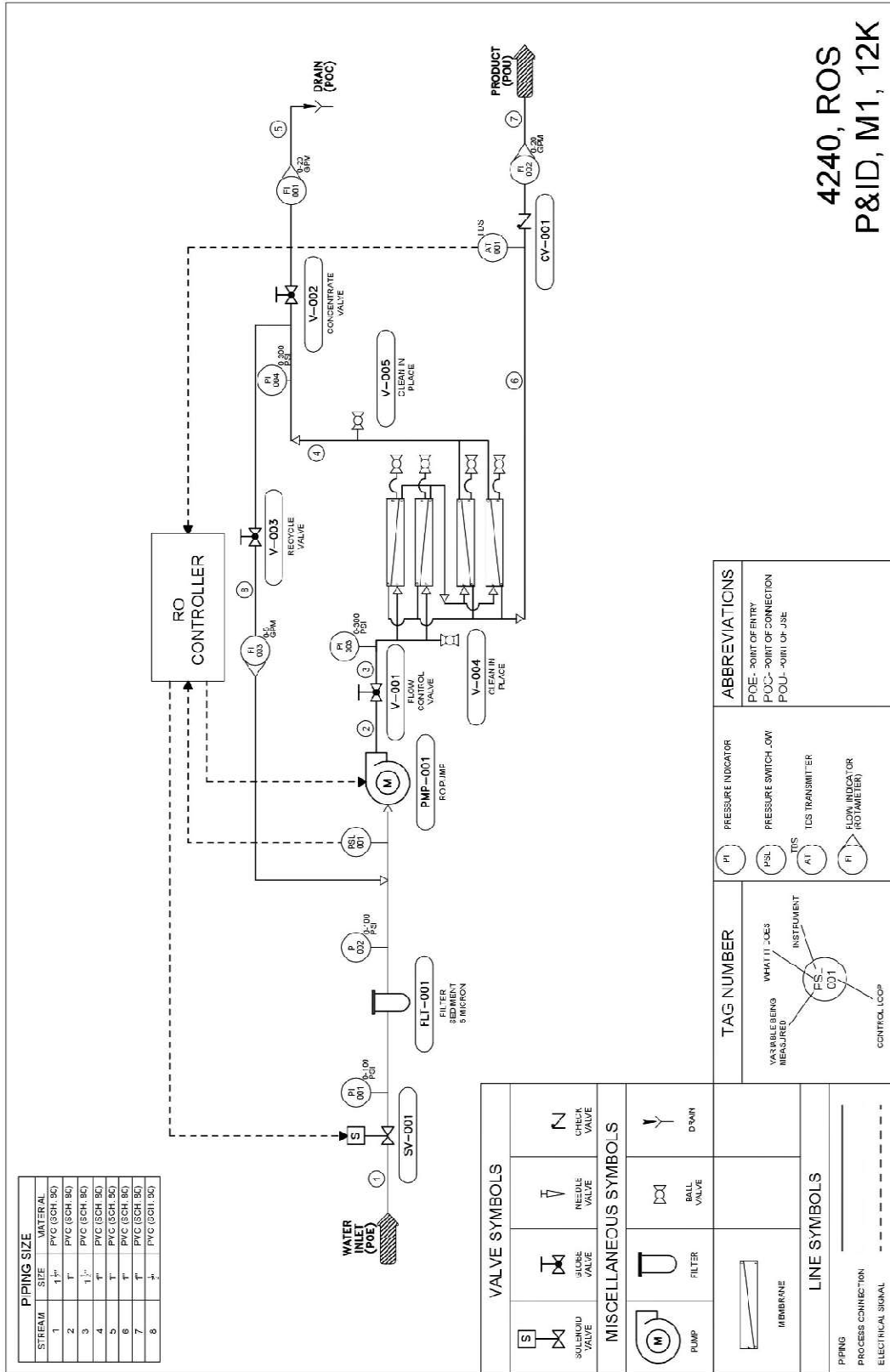

4240, ROS
P&ID, M1, 12K

M1-6240 FLOW DIAGRAM

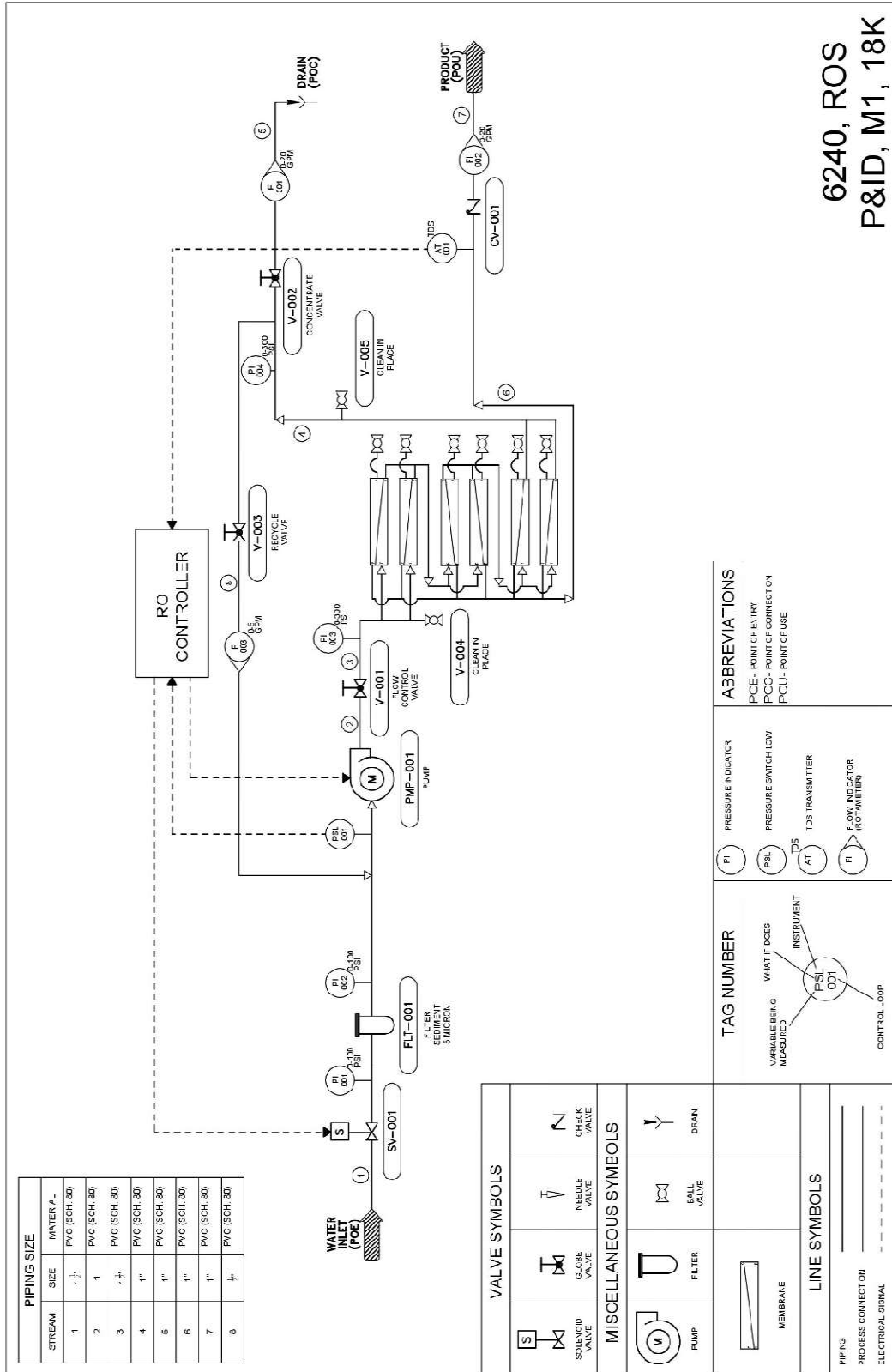

M1-8240 FLOW DIAGRAM

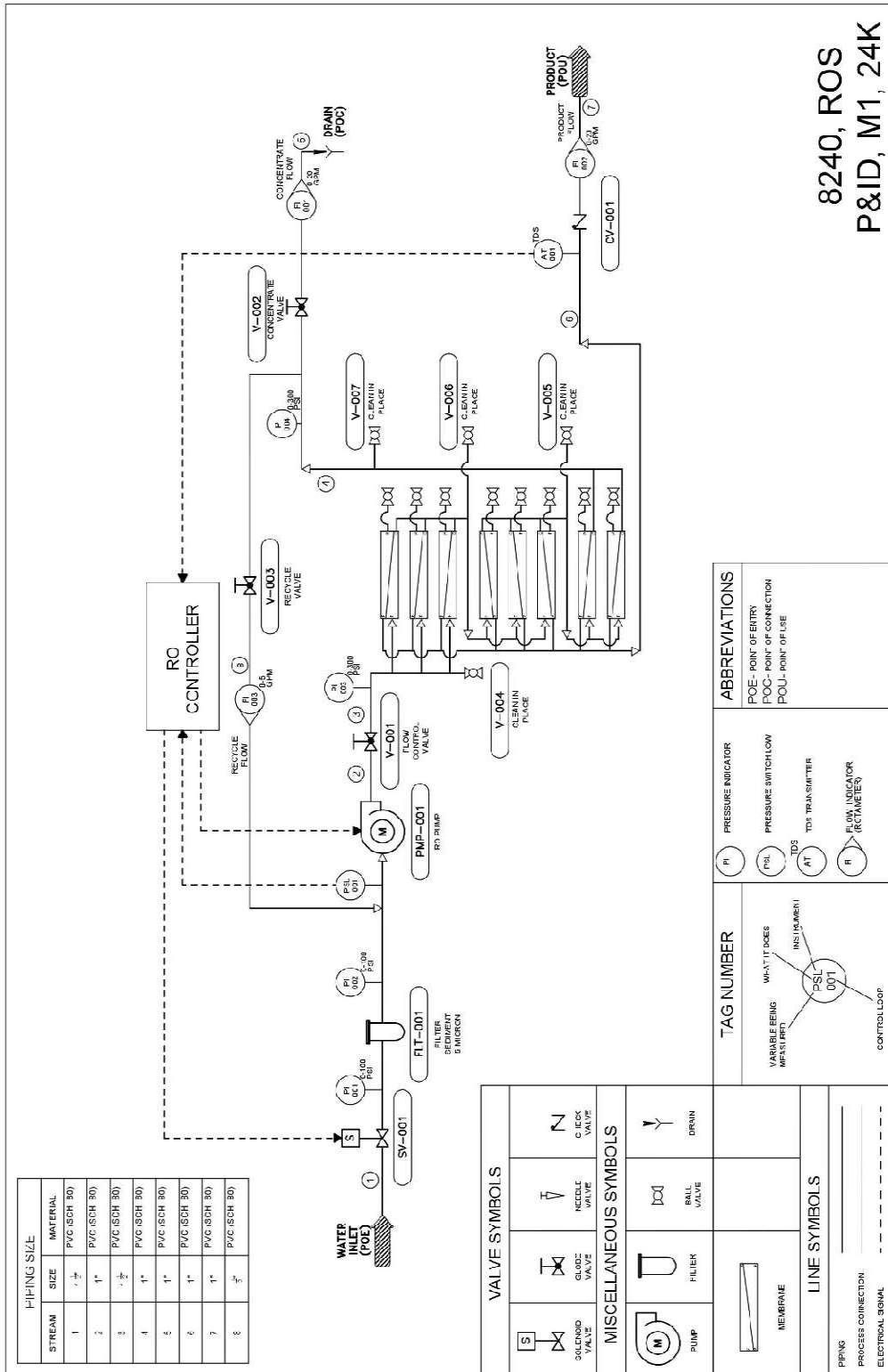

PIPING SIZE		MATERIAL
STREAM	SIZE	MATERIAL
1	1/2"	PVC (SCH 30)
2	1"	PVC (SCH 30)
3	1/2"	PVC (SCH 30)
4	1"	PVC (SCH 30)
5	1"	PVC (SCH 30)
6	1"	PVC (SCH 30)
7	1"	PVC (SCH 30)
8	3/4"	PVC (SCH 30)

VALVE SYMBOLS	MISCELLANEOUS SYMBOLS	TAG NUMBER	ABBREVIATIONS
SOLENOID VALVE	CHECK VALVE	VARIABLE BEING MEASURED	PI - PRESSURE INDICATOR
RECYCLE VALVE	BALL VALVE	WHAT IT DOES	PSL - PRESSURE SWITCH LOW
GLOBE VALVE	FILTER	INSTRUMENT	AT - TDS TRANSMITTER
PUMP	MEMBRANE	CONTROL LOOP	RI - RECYCLE INDICATOR
DRAIN	LINE SYMBOLS		
	PPING		
	PROCESS CONNECTION		
	ELECTRICAL SIGNAL		

M1-10240 FLOW DIAGRAM

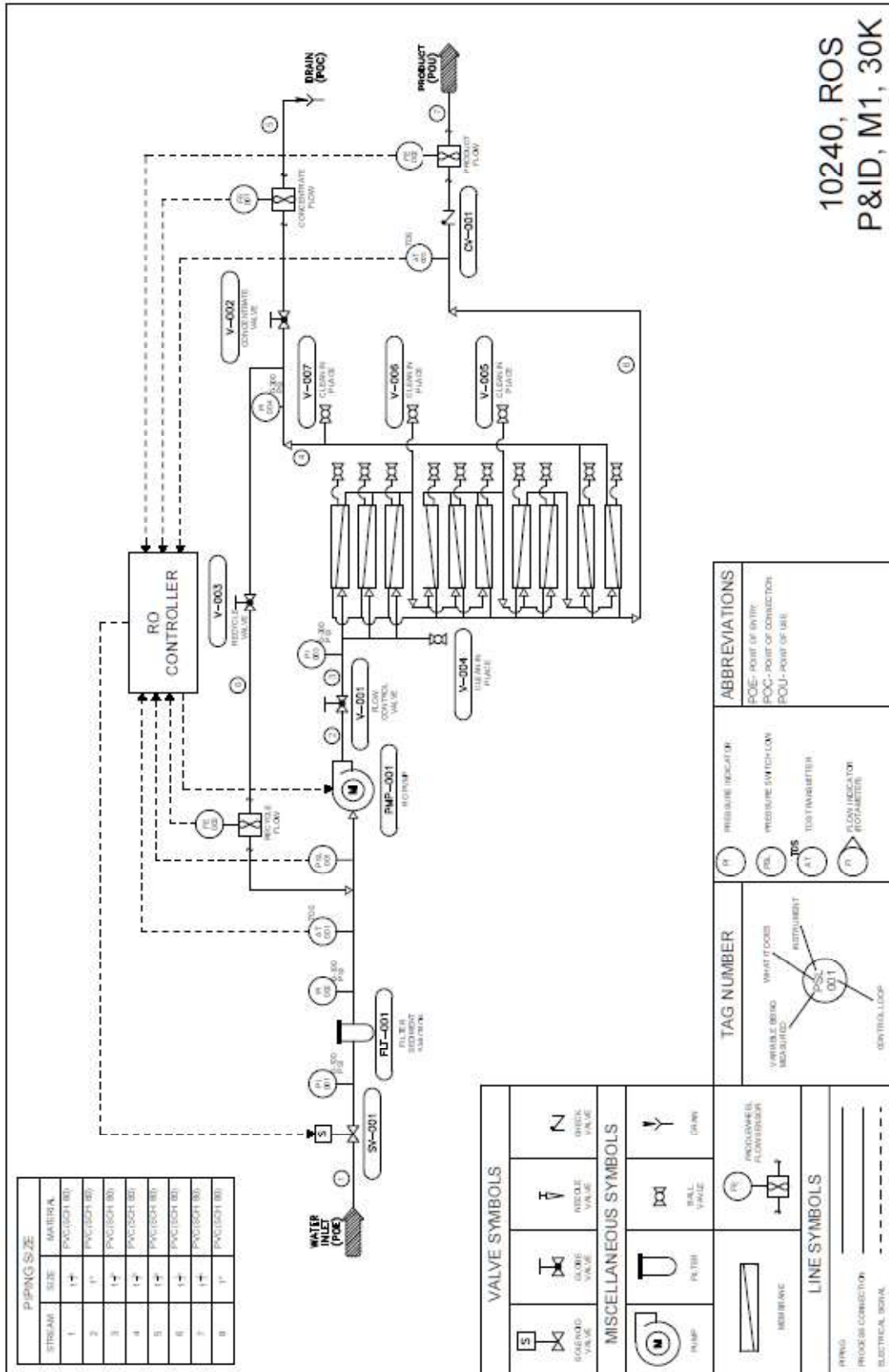

10240, ROS
P&ID, M1, 30K

M1-12240 FLOW DIAGRAM

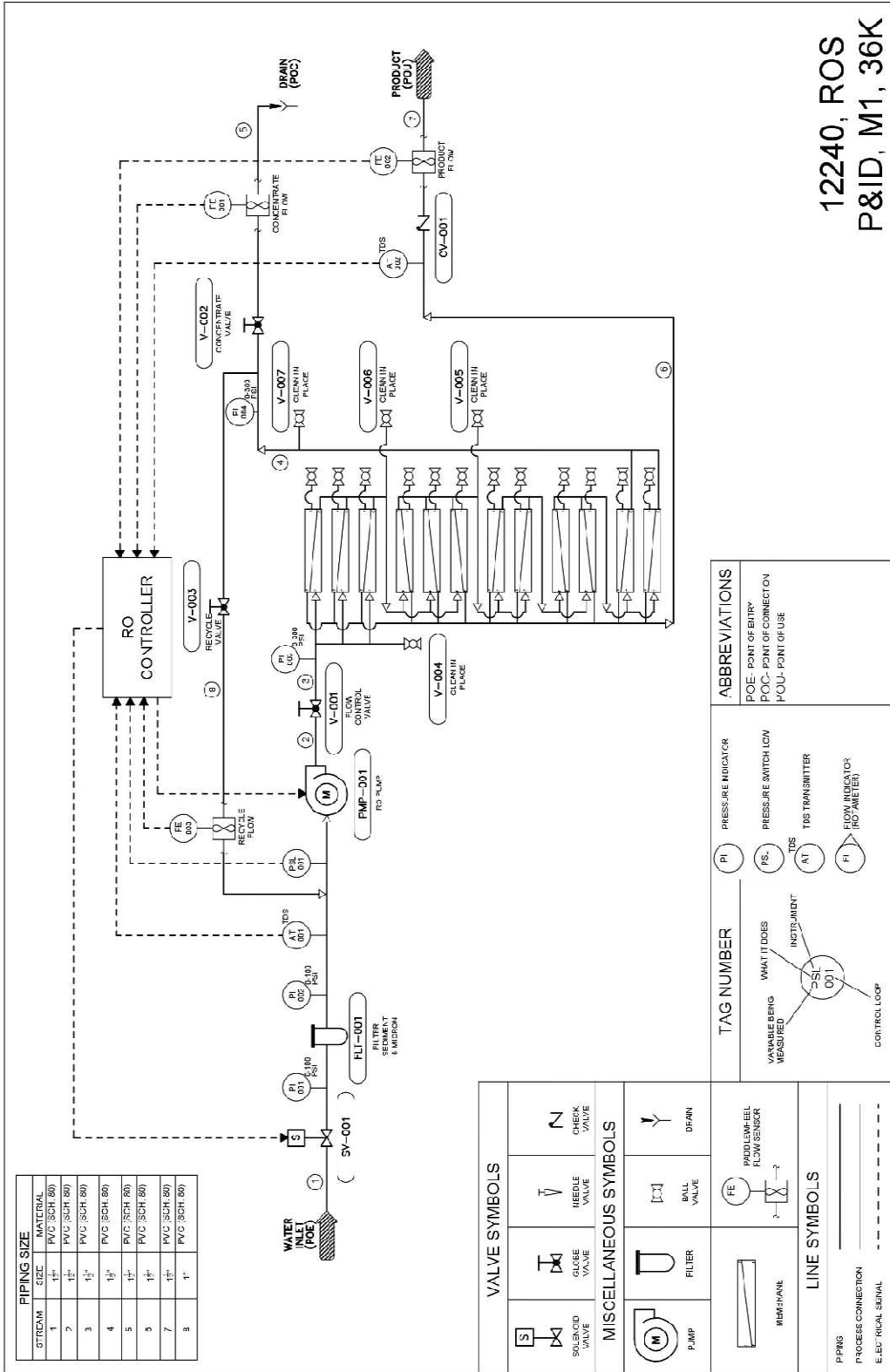

PIPING SIZE		
STREAM	SIZE	MATERIAL
1	1"	PVC (SCH. 80)
2	1 1/4"	PVC (SCH. 80)
3	1 1/2"	PVC (SCH. 80)
4	1 1/4"	PVC (SCH. 80)
5	1 1/4"	PVC (SCH. 80)
6	1 1/4"	PVC (SCH. 80)
7	1 1/4"	PVC (SCH. 80)
8	1"	PVC (SCH. 80)

12240, ROS
P&ID, M1, 36K

VALVE SYMBOLS	
	SOLENOID VALVE
	NEEDLE VALVE
	CHECK VALVE
MISCELLANEOUS SYMBOLS	
	FILTER
	PUMP
	MEMBRANE
	PRESSURE INDICATOR
	PRESSURE SWITCH LOW
	TDS TRANSMITTER
	FLOW INDICATOR (FLOW METER)
LINE SYMBOLS	
	PROCESS CONNECTION
	ELECTRICAL SIGNAL

TAG NUMBER		ABBREVIATIONS	
PH	PRESSURE INDICATOR	POE	POINT OF ENTRY
PS	PRESSURE SWITCH LOW	POC	POINT OF CONNECTION
TDS	TDS TRANSMITTER	POU	POINT OF USE
PI	FLOW INDICATOR (FLOW METER)		

ELECTRICAL SCHEMATICS

S – 150 220VAC 3HP 3PH 60/60HZ

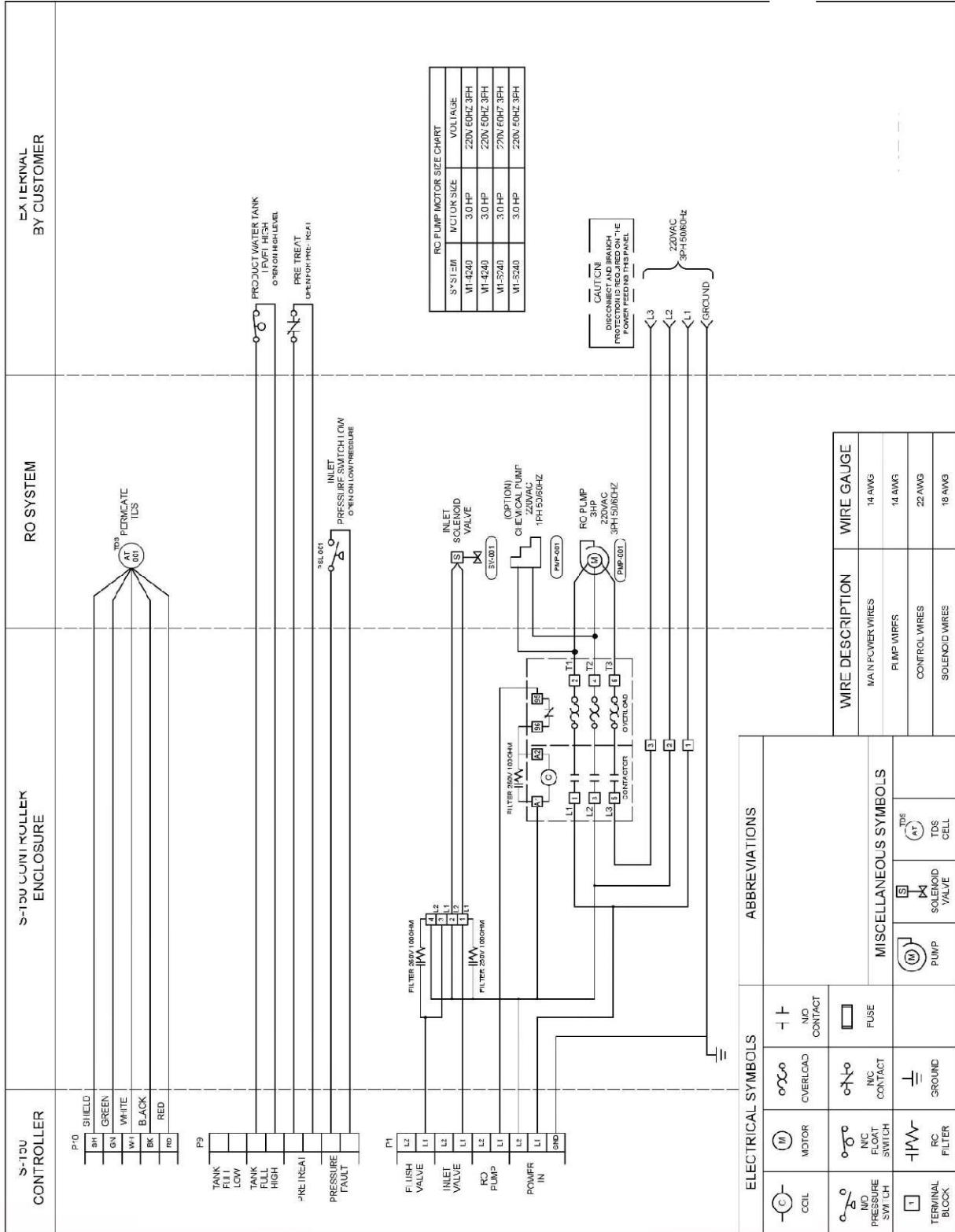

S-150 220VAC 5HP 3PH 50/60HZ

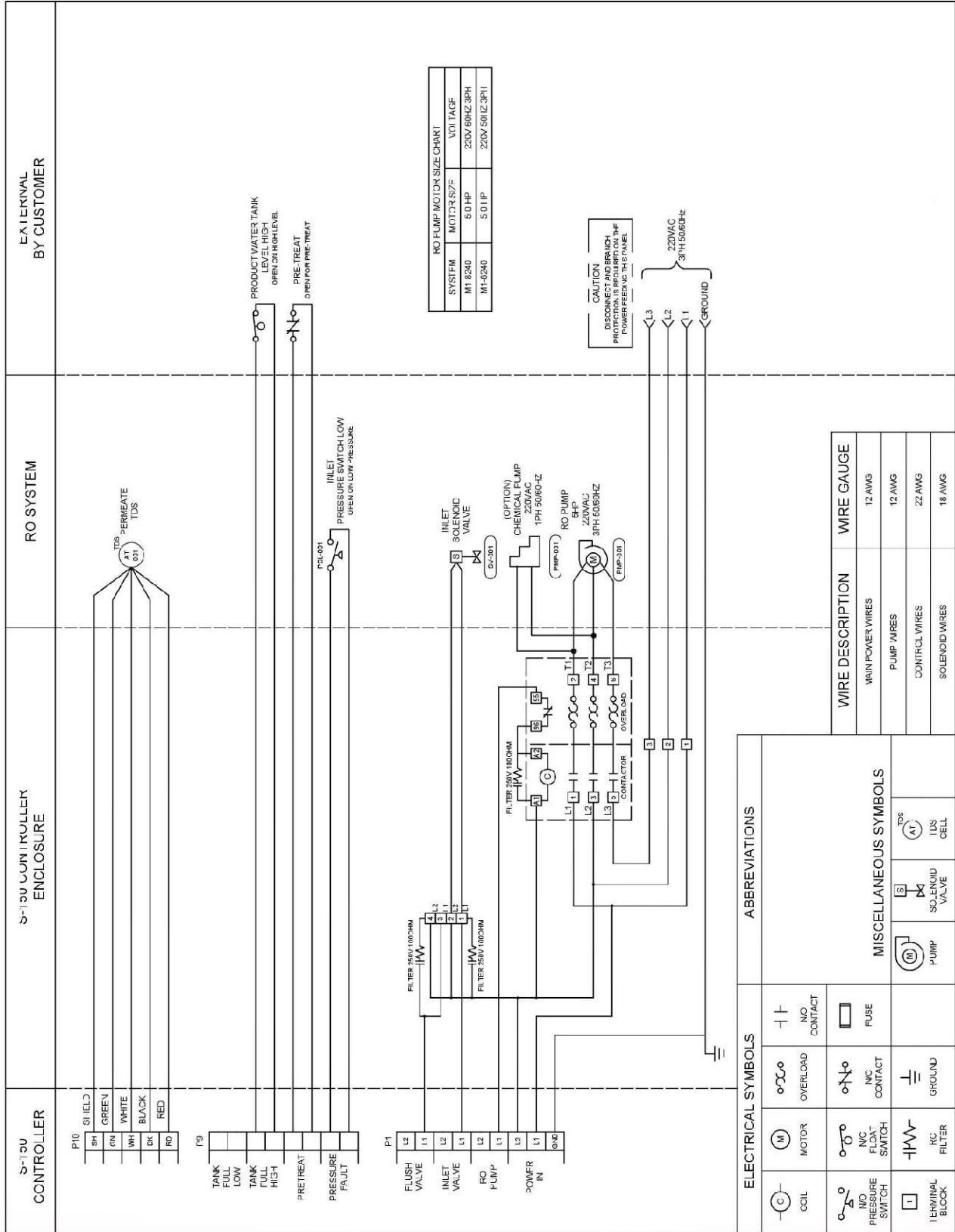

S-200 220VAC 3PH 60HZ

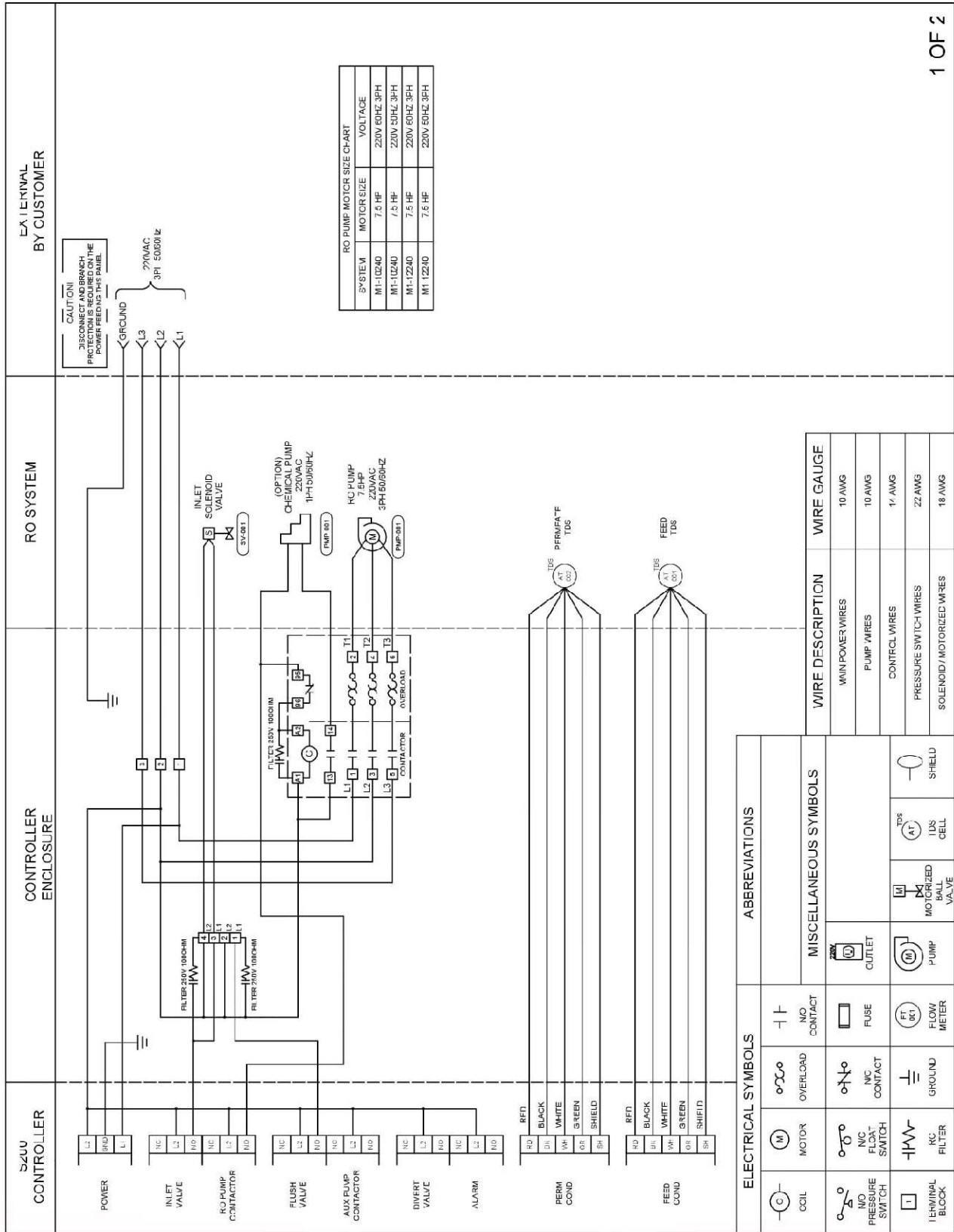

S-200 240VAC 3PH 60HZ

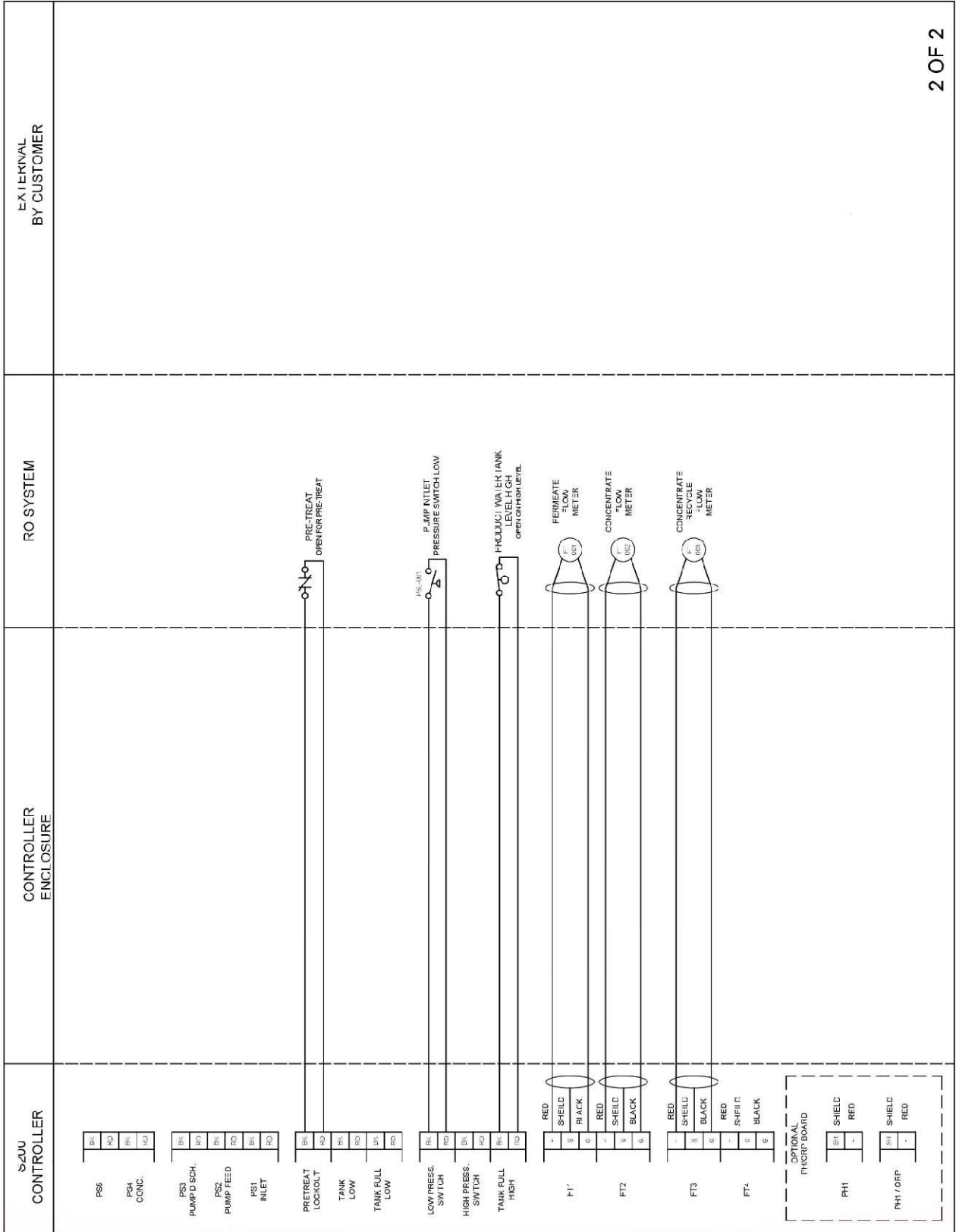

S-150 460VAC 3HP 3PH 60HZ

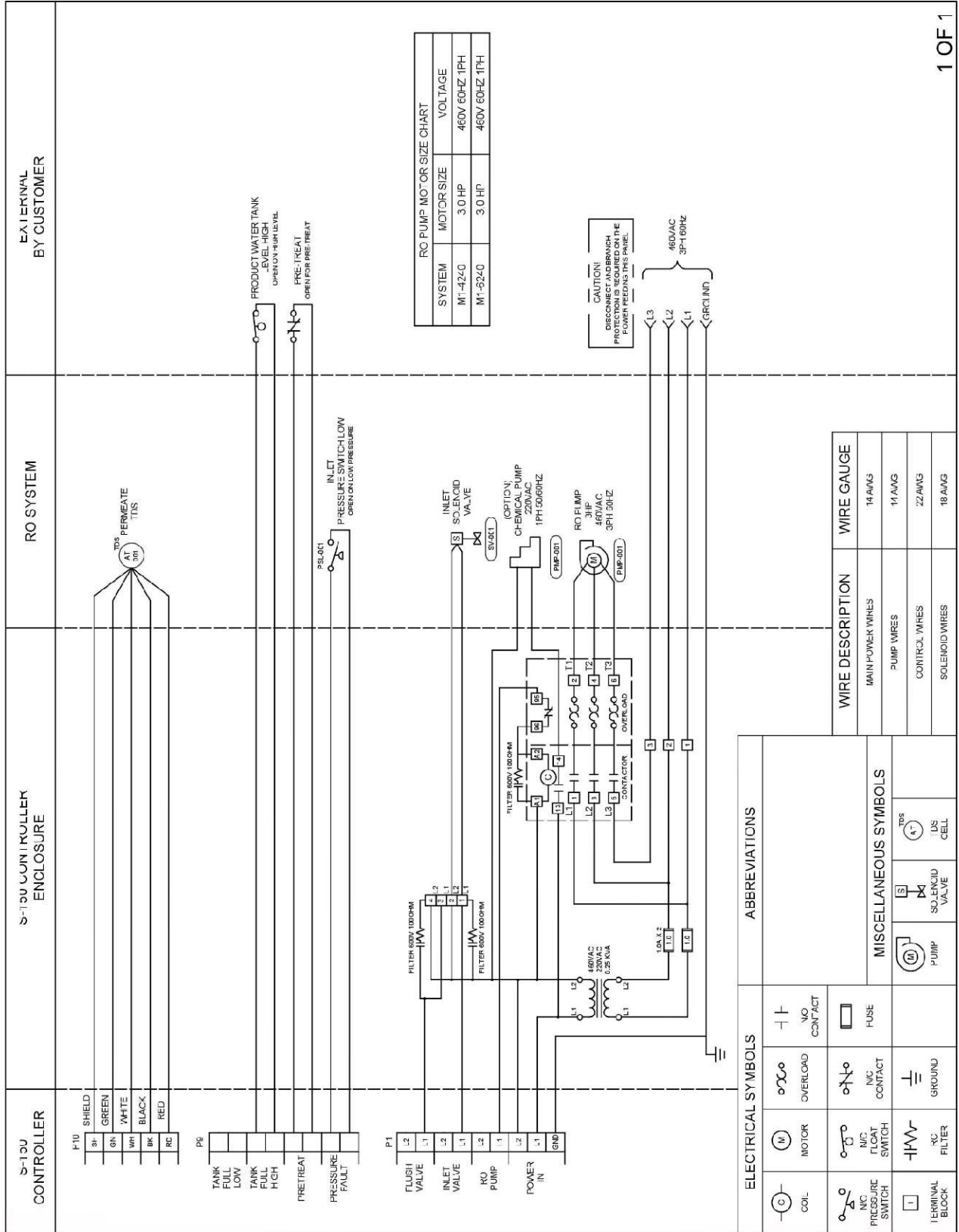

S-150 260VAC 5HP 3PH 60HZ

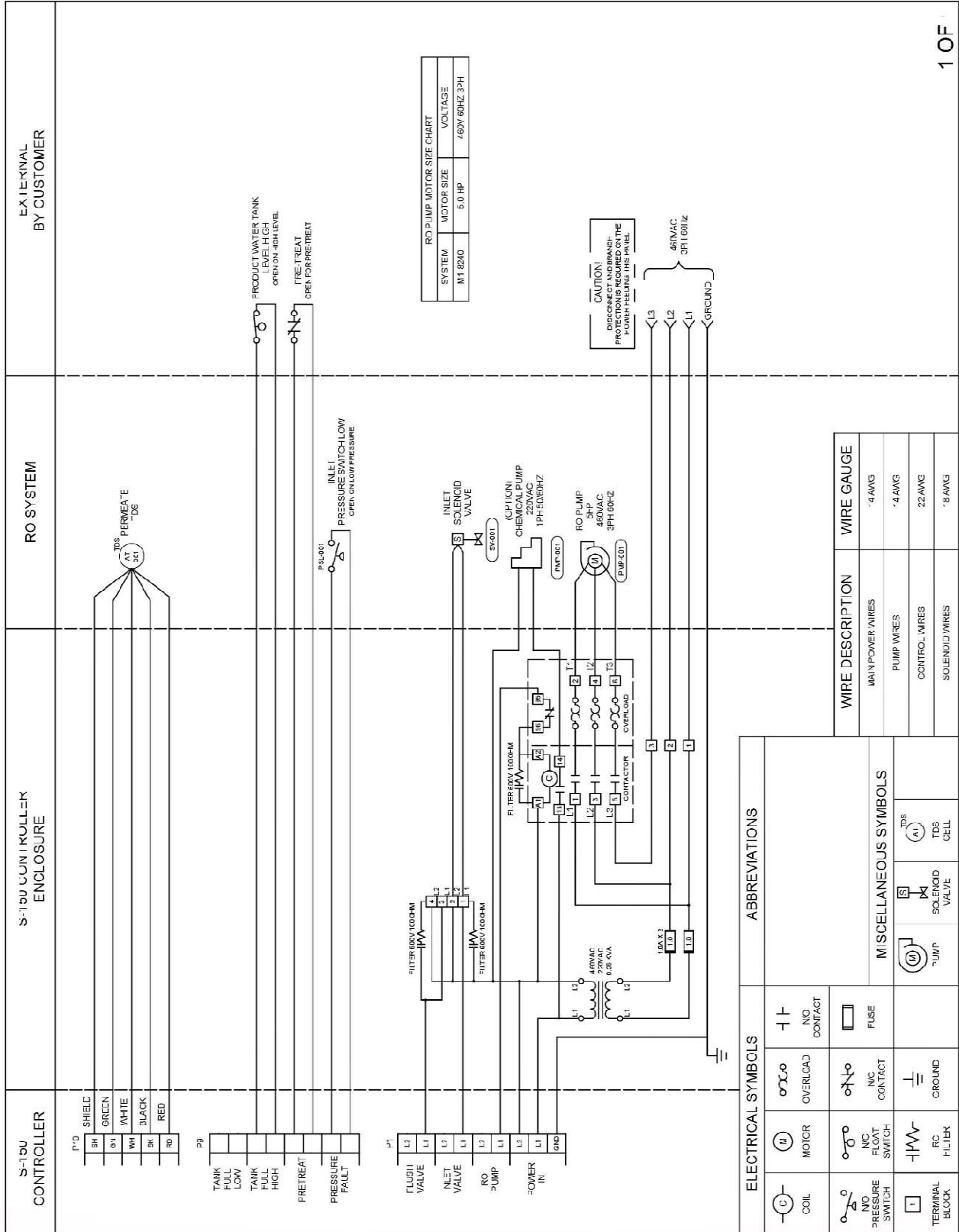

S-200 460VAC 3PH 60HZ

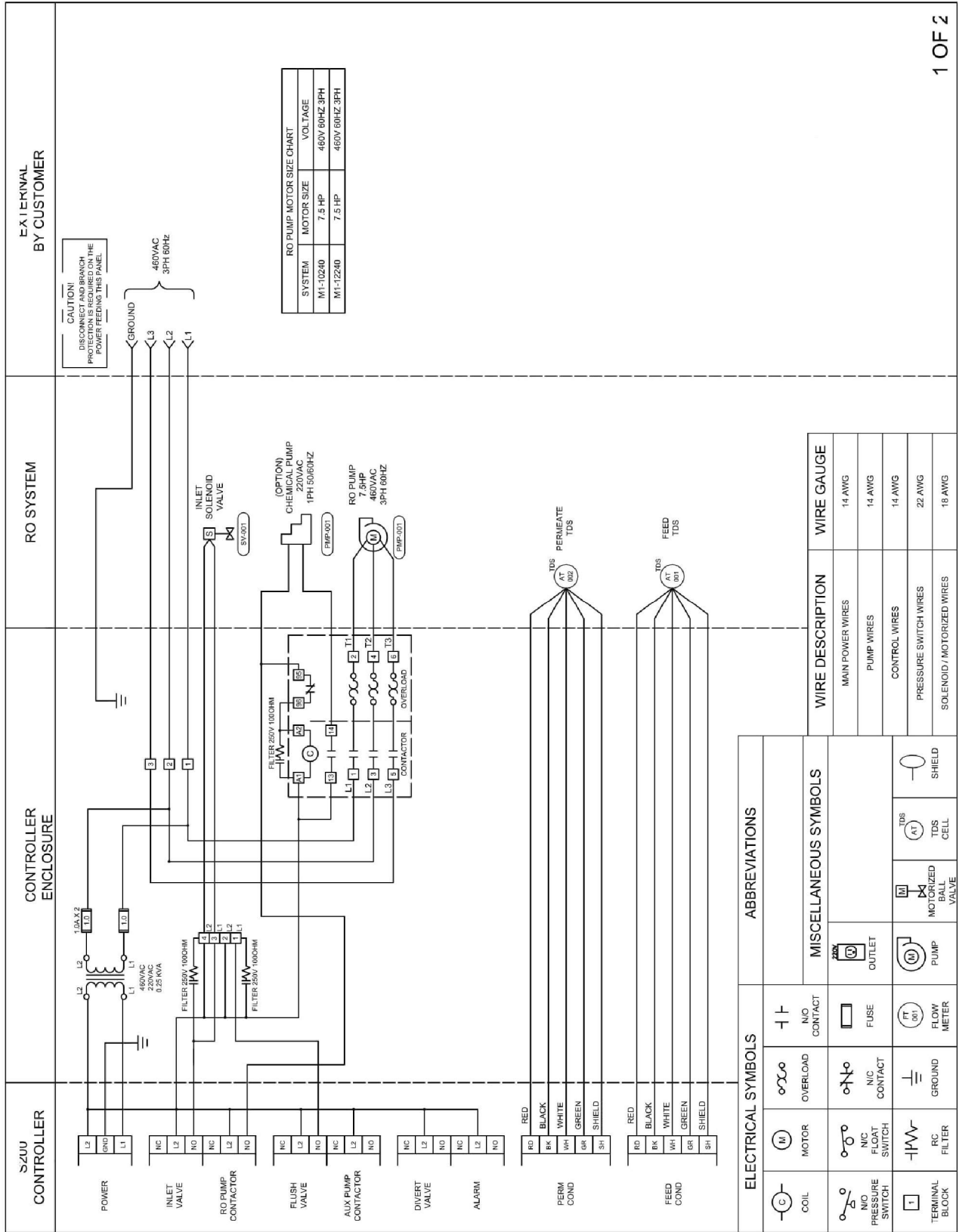

S-200 460VAC 3PH 60HZ

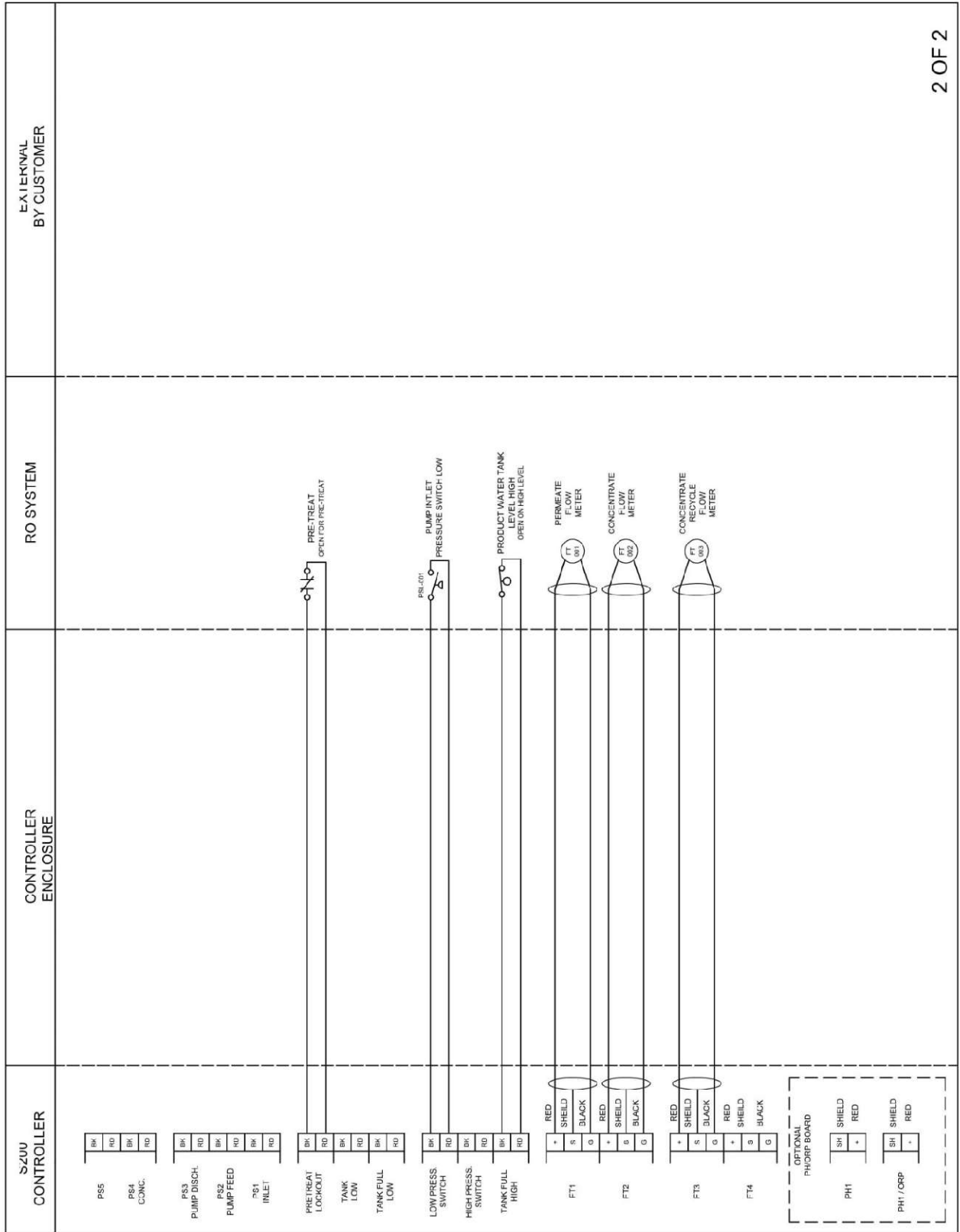

System Warranty

One-Year Limited Warranty

Warranty Terms

Subject to the terms and conditions set forth hereinafter, the manufacturer (hereafter "Manufacturer") warrants to the original purchaser (hereafter the "Customer") that the systems and products manufactured by the Manufacturer are free from defects in material and in workmanship for twelve (12) months from the Warranty Commencement Date (as defined below) only when used strictly in accordance with the applicable operating instructions and within the range of the operating conditions specified by the Manufacturer for each such product.

This Warranty does not extend to systems, equipment, or components manufactured by others, nor to systems, equipment, or components manufactured by others and distributed by the Manufacturer. This Warranty does not extend to equipment or components manufactured by others which have been incorporated into a Manufacturer product but, if allowable the, Manufacturer hereby assigns, without warranty, to the Customer its interest, if any, under any Warranty made by the Manufacturer of such equipment or component. This Warranty does not cover disposable items such as fuses, o-rings, regeneration materials/chemicals, or other such disposable items, which must be replaced periodically under the normal and foreseeable operating conditions of the goods warranted hereby.

Warranty Commencement Date

The Warranty Commencement Date for each Manufacturer product shall be the later of the date of: (1) receipt by the Customer, or (2) the date of installation at the Customer's premises provided that such installation must occur within three (3) months of shipment from the Manufacturer's manufacturing facility. In no event shall the Warranty Commencement Date exceed three (3) months from the shipment from the Manufacturer's manufacturing facility. The Customer shall provide proof of purchase in order to exercise rights granted under this Warranty. If requested by the Manufacturer, the Customer must also provide proof of the installation date. Proof of installation shall be returned by Customer to the Manufacturer within thirty (30) days after installation by virtue of supplying a Warranty Validation Card supplied with each Manufacturer product fully completed and signed in ink by Customer and the authorized installer of the product.

Warranty Service

THE MANUFACTURER'S OBLIGATION UNDER THIS WARRANTY IS LIMITED TO THE REPAIR OR REPLACEMENT (AT MANUFACTURER'S SOLE DISCRETION) OF ANY PRODUCT, OR COMPONENT THEREOF, PROVED TO BE DEFECTIVE IN MATERIAL OR WORKMANSHIP WITHIN THE COVERED WARRANTY PERIOD.

The Customer, at the Customer's risk and expense, shall be responsible for returning such product or component, only after obtaining a Return Goods Authorization (RGA) number from the Manufacturer, arranging for freight prepaid, and in conformance with any special packaging and shipping instructions set forth on the operation documentation or RGA instructions, or as otherwise reasonably required, to the Manufacturer, together with (1) RGA number issued by the Manufacturer at Customer's request; (2) proof of purchase and, if necessary, proof of installation date; (3) a Return Goods Authorization Form; (4) a description of the suspected defects; (5) the serial number of the Manufacturer product alleged to be defective; and (6) a description of the type of water and pretreatment equipment which has been utilized in connection with the product, if any. The Manufacturer shall, in the Manufacturer's reasonable discretion, be the sole judge of whether a returned product or component is defective in material or workmanship. Required or replaced products or components shall be returned surface freight. In genuine emergency situations, the Manufacturer will (at the Manufacturer's sole discretion) forward replacement parts to the

Customer without waiting for authorized return of the questionable part(s). In such cases, Customer will issue a purchase order or other payment guarantee prior to shipment. If the returned part is found to have been misused or abused, or the defective part is not received by the Manufacturer within thirty (30) days; the Customer will be invoiced for the replacement part(s) provided. This Warranty does not cover or include labor and/or travel to the Customer's premise or location or any other location. Charges of \$1000 per day plus associated travel expenses will be incurred by the Customer in providing the Warranty Service at any location other than the Manufacturer's main headquarters; that is if the Manufacturer deems that the product is not covered by said Warranty. The Manufacturer reserves the right to precondition such travel to Customer's premises upon prepayment of the Manufacturer's anticipated costs of attending such premises.

Voidability of Warranty

This Warranty shall be void and unenforceable as to any Manufacturer product which has been damaged by accident, mishandling, abuse or has been repaired, modified, altered, disassembled or otherwise tampered with by anyone other than the Manufacturer or an authorized Manufacturer service representative; or, if any replacement parts are not authorized by the Manufacturer have been used, or, the product has not been installed, operated and maintained in strict accordance and adherence with the operating documentation and manuals for such product. Any expressed Warranty, or similar representation of performance set forth in the operation documentation for media or resin incorporated into the Manufacturer product shall be void and unenforceable unless the feed water requirements set forth in the operating documentation for such product are unequivocally and strictly adhered to.

Limitations and Exclusions

THIS WARRANTY AND REMEDIES DESCRIBED HEREIN AND HEREINABOVE ARE EXCLUSIVE AND IN LIEU OF ANY AND ALL OTHER WARRANTY OR REMEDIES, EXPRESSED OR IMPLIED, INCLUDING WITHOUT LIMITATION, ANY IMPLIED WARRANTY OF MERCHANTABILITY OR FITNESS FOR A PARTICULAR PURPOSE. IN NO EVENT SHALL THE MANUFACTURER BE LIABLE FOR ANY CONSEQUENTIAL, INCIDENTAL OR OTHER SIMILAR TYPES OF DAMAGES, DAMAGES FOR THE LOSS OF PRODUCTION OR PROFITS, OR INJURY TO PERSON OR PROPERTY. NO PERSON HAS ANY AUTHORITY TO BIND THE MANUFACTURER TO OTHER THAN WHAT IS SET FORTH ABOVE.

THIS WARRANTY GIVES THE CUSTOMER SPECIFIC LEGAL RIGHTS AND THE CUSTOMER MAY ALSO HAVE OTHER RIGHTS WHICH VARY FROM JURISDICTION TO JURISDICTION. THE PARTIES RECOGNIZE AND AGREE, THAT IN ALL RESPECTS THE LAWS OF THE STATE OF CALIFORNIA SHALL APPLY TO AND SHALL GOVERN ANY INTERPRETATION OR LEGAL SIGNIFICANCE OF THIS DOCUMENT.

NO WARRANTY OR OTHER LIABILITY OF THE MANUFACTURER TO CUSTOMER UNDER THIS AGREEMENT OR OTHERWISE WILL IN ANY EVENT EXCEED THE COST OF REPLACEMENT OF THE APPLICABLE MANUFACTURER PRODUCT, PART, OR ACCESSORY THAT IS SUBJECT TO ANY BREACH OF THE MANUFACTURER'S WARRANTY. THE MANUFACTURER WILL NOT BE LIABLE FOR ANY DAMAGE TO ANY PROPERTY OF CUSTOMER OR TO CUSTOMER'S CUSTOMERS FOR ANY CONSEQUENTIAL, INCIDENTAL, OR ECONOMIC LOSS OR COMMERCIAL DAMAGE WHATSOEVER. REMEDIES HEREIN PROVIDED ARE EXPRESSLY MADE THE SOLE AND EXCLUSIVE REMEDIES FOR BREACH OF ANY WARRANTY OR OTHER OBLIGATION HEREUNDER EXPRESS OR IMPLIED OR FROM THE OPERATION OF LAW.

This Page Intentionally
Left Blank