

# M2-SERIES REVERSE OSMOSIS SYSTEMS

**AXEON® M2-Series Reverse Osmosis Systems** are a line of high capacity systems with flows ranging from 12,000 to 36,000 gallons per day. These systems are ideal for removing the salt content in well water and surface water for use in commercial and light industrial applications. Using an efficient high pressure pump, the M2-Series systems are engineered for treating brackish water with levels of 10,000 ppm.



**M2-12240**  
Reverse Osmosis System

**M2-Series Reverse Osmosis Systems** feature a computer controller that has dual TDS monitoring, low pressure monitoring and alarm, pretreatment lockout, and feed flush and tank level input while larger models include an additional digital flow monitor. All models include low energy reverse osmosis membrane elements, motorized feed valve, permeate sample ports and a bag filter housing with a 5-Micron filter bag.

Some options available for the M2-Series include permeate flush, permeate divert, variable frequency drive, chemical injection system and clean-in-place system.

## BENEFITS

- Fully Equipped and Customizable
- Skid Mounted
- Components Easily Accessible
- Pre-Plumbed, Wired and Assembled
- Individually Tested and Preserved
- Low Operation and Maintenance Costs
- Easy Maintenance and Servicing
- 20% Less Energy
- 1-Year Limited Warranty

### AXEON Naming Matrix

	<b>M2</b>	<b>12</b>	<b>2</b>	<b>40</b>
<b>M-Series Model</b>				
M2	Brackish Water Model			
<b>Housing Quantity Designation</b>				
4	4 Vessels			
6	6 Vessels			
8	8 Vessels			
10	10 Vessels			
12	12 Vessels			
<b>Membrane Quantity Per Housing</b>				
2	2 Membranes			
<b>4.0 Inch Membrane Diameter</b>				

## FEATURES

### Models: M2-4240, M2-6240, M2-8240

- S-150 Computer Controller
  - LCD Backlit Display
  - Pre-Treatment Lockout
  - Tank Level Input
  - Hour Meter
  - Low and High Pressure Monitoring and Alarm
  - Dual TDS Monitoring
  - Feed Flush
  - Rejection Percentage

### Models: M2-10240, M2-12240

- S-200 Computer Controller
  - LCD Backlit Display
  - Pre-Treatment Lockout
  - Tank Level Input
  - Low and High Pressure Monitoring and Alarm
  - Hour Meter
  - Dual TDS Monitoring
  - Feed Flush
  - Digital Flow Meters (2)
  - Rejection Percentage
  - Recovery Percentage
- AXEON Permeate and Concentrate Flow Meters<sup>A</sup>
- Stainless Steel Concentrate Globe Valve
- AXEON Pre-Filter 0-100 psi Panel Mounted Glycerin Filled Gauges
- AXEON Pump Discharge 0-600 psi Panel Mounted Glycerin Filled Stainless Steel Gauges
- Pentair® 5-Micron Filter Bag
- Pentair® Bag Filter Housing
- AXEON FRP-Series Membrane Housings (450 psi)
- Vertical Multi-Stage 316L Stainless Steel Booster Pump
- Filmtec® LCLE Membrane Elements

**M2-12240**  
Reverse Osmosis System



### Models: M2-10240, M2-12240 (continued)

- George Fisher® Motorized Valve
- Feed Low Pressure Switch
- Pump High Pressure Switch
- Clean-In-Place (CIP) Ports
- Victaulic® Style Fittings
- Permeate Sample Ports
- High Pressure Stainless Steel Piping and Fittings
- White Powder Coated Aluminum Frame
- Wooden Shipping Crate

## OPTIONS AND UPGRADES

### Models: M2-4240, M2-6240, M2-8240

- S-150 Expander Board<sup>A</sup>
- S-200 Computer Controller<sup>A</sup>
- S-200 pH Monitoring<sup>A</sup>
- S-200 ORP Monitoring<sup>A</sup>
- Variable Frequency Drive<sup>B</sup>
- Filmtec® LCHR Membrane Elements
- High Pressure Tank Switch
- Hanna® BL 981411 pH Controller<sup>A</sup>
- Hanna® BL 982411 ORP Controller<sup>A</sup>
- Chemical Pump Outlet
- Blending Valve
- Permeate Divert Valve
- Pump Pressure Relief Valve<sup>B</sup>
- Caster Wheels

A. Only available on the following models: M1-4240, M1-6240, M1-8240  
B. Standard for all 50Hz Systems

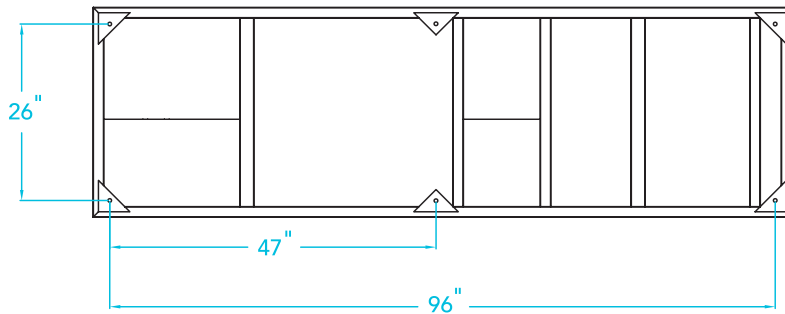
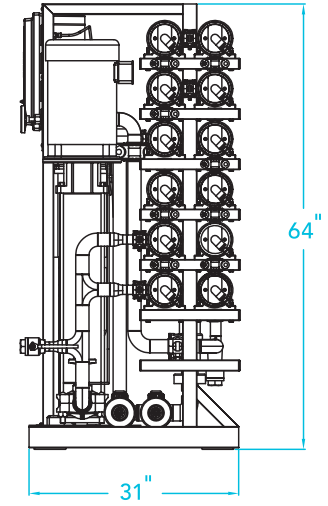
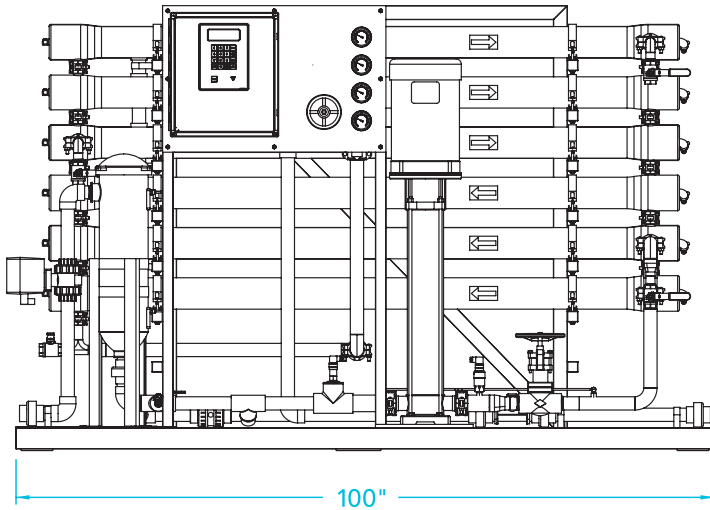

**Notes:**

1. All dimensions are given in inches.
2. Model M2-12240 AXEON model shown.

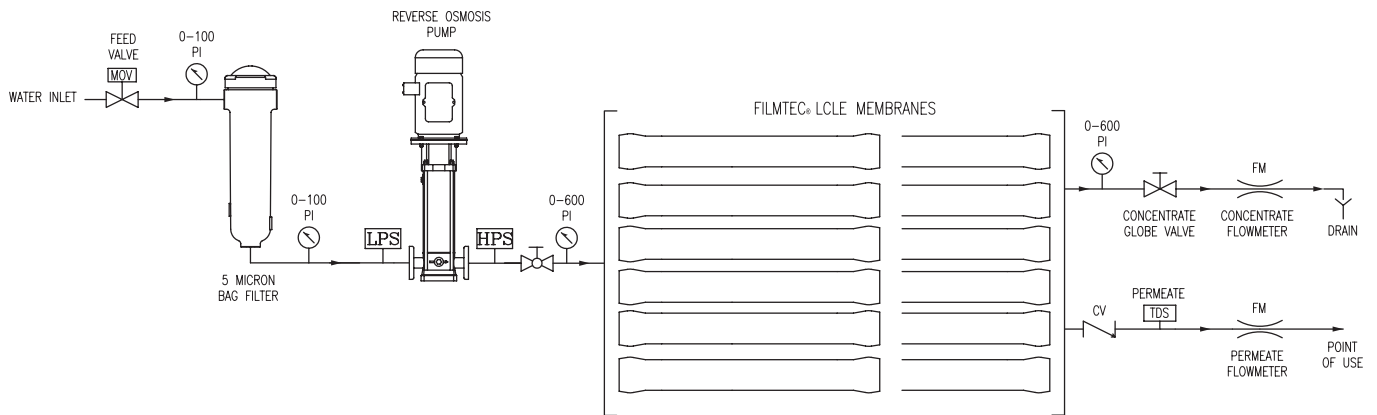

## ARRAY SPECIFICATIONS

Model	Vessel Array	Vessel Size	Vessel Quantity	Membrane Size	Membrane Quantity
M2-4240	2:2	4080	4	4040	8
M2-6240	2:2:2	4080	6	4040	12
M2-8240	3:3:2	4080	8	4040	16
M2-10240	3:3:2:2	4080	10	4040	20
M2-12240	3:3:2:2:2	4080	12	4040	24

# SPECIFICATIONS

MODELS	M2-4240	M2-6240	M2-8240	M2-10240	M2-12240
<b>Design</b>					
Configuration	Single Pass	Single Pass	Single Pass	Single Pass	Single Pass
Feedwater Source <sup>C</sup>	TDS < 10,000 ppm	TDS < 10,000 ppm	TDS < 10,000 ppm	TDS < 10,000 ppm	TDS < 10,000 ppm
Standard Recovery Rate %	40-50	40-50	40-50	30-45	46-52
<b>Rejection and Flow Rates<sup>D</sup></b>					
Nominal Salt Rejection %	99.2	99.2	99.2	99.2	99.2
Permeate Flow <sup>E</sup> (gpm / lpm)	8.30 / 31.41	12.50 / 47.31	16.70 / 63.21	20.80 / 78.74	25.00 / 94.63
Minimum Feed Flow (gpm / lpm)	14.30 / 54.13	18.50 / 70.03	22.70 / 85.93	26.80 / 101.45	31.00 / 117.35
Maximum Feed Flow (gpm / lpm)	28 / 106	28 / 106	42 / 159	42 / 159	42 / 159
Minimum Concentrate Flow (gpm / lpm)	6 / 23	6 / 23	6 / 23	6 / 23	6 / 23
<b>Connections</b>					
Feed FNPT (in)	1.5	1.5	1.5	1.5	1.5
Permeate FNPT (in)	1	1	1	1.5	1.5
Concentrate FNPT (in)	1	1	1	1.5	1.5
CIP FNPT (in)	1	1	1	1	1
<b>Membranes</b>					
Membranes Per Vessel	2	2	2	2	2
Membrane Quantity	8	12	16	20	24
Membrane Size	4040	4040	4040	4040	4040
<b>Vessels</b>					
Vessel Array	2:2	2:2:2	3:3:2	3:3:2:2	3:3:2:2:2
Vessel Quantity	4	6	8	10	12
<b>Pumps</b>					
Pump Type	Multi-Stage	Multi-Stage	Multi-Stage	Multi-Stage	Multi-Stage
Motor HP	7.5	7.5	10	10	15
RPM @ 60Hz	3450	3450	3450	3450	3450
RPM @ 50Hz	VFD at 60Hz	VFD at 60Hz	VFD at 60Hz	VFD at 60Hz	VFD at 60Hz
<b>System Electrical</b>					
Standard Voltage + Amp Draw	220V, 60Hz, 3PH, 19.5A <sup>E</sup>	220V, 60Hz, 3PH, 19A <sup>E</sup>	220V, 60Hz, 3PH, 26.6A <sup>E</sup>	220V, 60Hz, 3PH, 26.6A <sup>E</sup>	220V, 60Hz, 3PH, 36A <sup>E</sup>
High Voltage Service + Amp Draw	220V, 50Hz, 3PH, 22.9A <sup>E</sup> 460V, 60Hz, 3PH, 9.7A <sup>E</sup>	220V, 50Hz, 3PH, 22.9A <sup>E</sup> 460V, 60Hz, 3PH, 9.7A <sup>E</sup>	220V, 50Hz, 3PH, 30.9A <sup>E</sup> 460V, 60Hz, 3PH, 12.9A <sup>E</sup>	220V, 50Hz, 3PH, 30.9A <sup>E</sup> 460V, 60Hz, 3PH, 12.9A <sup>E</sup>	220V, 50Hz, 3PH, 45A <sup>E</sup> 460V, 60Hz, 3PH, 18.5A <sup>E</sup>
<b>System Dimensions</b>					
Approximate Dimensions <sup>F</sup> L x W x H (in / cm)	31 x 100 x 64 / 787.4 x 2540 x 1626	31 x 100 x 64 / 787.4 x 2540 x 1626	31 x 100 x 64 / 787.4 x 2540 x 1626	31 x 100 x 64 / 787.4 x 2540 x 1626	31 x 100 x 64 / 787.4 x 2540 x 1626
Approximate Weight (lbs / kg)	1260 / 572	1350 / 611	1460 / 662	1550 / 703	1650 / 748

**Test Parameters:** 10,000 TDS Filtered (5-Micron), Dechlorinated, Municipal Feedwater, 65 psi / 4.50 bar Feed Pressure, 350 psi / 24.13 bar Operating Pressure, 77°F / 25°C, Recovery as stated, 7.0 pH. Data taken after 60 minutes of operation.

C. Low temperatures and feedwater quality, such as high TDS levels will significantly affect the systems production capabilities and performance. Computer projections must be run for individual applications which do not meet or exceed minimum and maximum operating limits for such conditions.

D. Product flow and maximum recovery rates are based on feedwater conditions as stated above. Do not exceed recommended permeate flow.

E. Varies with motor manufacturer.

F. Does not include operating space requirements.

## OPERATING LIMITS<sup>G</sup>

Maximum Feed Temperature (°F / °C)	85 / 29	Maximum Turbidity (NTU)	1
Minimum Feed Temperature (°F / °C)	40 / 4	Maximum Free Chlorine (ppm)	0
Maximum Ambient Temperature (°F / °C)	120 / 49	Maximum TDS (ppm)	10,000
Minimum Ambient Temperature (°F / °C)	40 / 4	Maximum Hardness (gpg)	0
Maximum Feed Pressure (psi / bar)	85 / 6	Maximum pH (continuous)	11
Minimum Feed Pressure (psi / bar)	45 / 3	Minimum pH (continuous)	2
Maximum Operating Pressure (psi / bar)	400 / 28	Maximum pH (cleaning 30 minutes)	13
Maximum Feed Silt Density Index (SDI)	< 3	Minimum pH (cleaning 30 minutes)	1

G. System pressure is variable due to water conditions. Permeate flow will increase at a higher temperature and will decrease at a lower temperature.

800-320-4074

AXEONwater.com

