

R2-SERIES REVERSE OSMOSIS SYSTEMS

AXEON® R2-Series Reverse Osmosis Systems are designed for durability and superior performance and are well-suited for treating well water and surface water containing dissolved solids up to 10,000 ppm. The R2-Series is specifically designed with a compact frame to fit into small areas such as utility rooms.

AXEON R2-Series Reverse Osmosis Systems have been engineered for capacities ranging from 1,500 to 9,000 gallons per day. These systems include a computer processor with standard control functions for dual TDS monitoring, low pressure monitoring with alarm, pre-treatment lockout, feed flush and tanklevel input. These models feature high quality components such as a stainless steel multi-stage high pressure pump, low energy membrane elements, membrane housings rated at 450 psi and a cartridge housing with a 5-micron sediment pre-filter.

Options available for the R2-Series include permeate divert, variable frequency drive, a chemical injection system and a clean-in-place system.



R2-6140
Reverse Osmosis System

BENEFITS

- Fully Equipped and Customizable
- Expandable and Skid Mounted
- Decreased Size of Dimensional Footprint
- Components Easily Accessible
- Pre-Plumbed, Wired and Assembled
- Individually Tested and Preserved
- Low Operation and Maintenance Costs
- Easy Maintenance and Servicing
- 1-Year Limited Warranty

AXEON Naming Matrix

	R2	6	1	40
R-Series Model				
R2 Brackish Water Model				
Housing Quantity Designation				
1	1 Vessel			
2	2 Vessels			
3	3 Vessels			
4	4 Vessels			
5	5 Vessels			
6	6 Vessels			
Membrane Quantity Per Housing				
1	1 Membrane			
4.0 Inch Membrane Diameter				

FEATURES

- S-150 Computer Controller
 - LCD Backlit Display
 - Pre-Treatment Lockout
 - Tank Level Input
 - High Pressure Monitoring with Alarm
 - Low Pressure Monitoring with Alarm
 - Dual TDS Monitoring
 - Feed Flush
- AXEON Permeate and Concentrate Flow Meters
- AXEON Pre-Filter 0-100 psi Panel Mounted Glycerin Filled Gauges
- AXEON Post-Filter 0-100 psi Panel Mounted Glycerin Filled Gauges
- AXEON 0-600 psi Glycerin-Filled Pump Discharge and Concentrate Pressure Gauges
- AXEON 5-Micron Sediment Pre-Filter
- Pentair® Single O-Ring Heavy-Duty Filter Housing
- Filmtec® LCLE Low Energy Membrane Elements
- AXEON FRP-Series Membrane Housings (450 psi)
- Permeate Sample Ports
- Vertical Multi-Stage Stainless Steel Booster Pump
- Plastomatic Feed Solenoid Valve
- Feed Low Pressure Switch
- Pump High Pressure Switch
- Clean-in-Place (CIP) Ports
- Victaulic® Style Fittings
- Permeate Sample Ports
- High Pressure Stainless Steel Tubing and Fittings
- White Powder Coated Aluminum Frame

OPTIONS AND UPGRADES

- S-150 Expander Board
- Variable Frequency Drive (VFD)
- Filmtec® LCHR Membrane Elements
- Pump Pressure Relief Valve
- Blending Valve
- Permeate Divert Valve
- Permeate Flush
- Chemical Pump Outlet
- Hanna® BL 981411 pH Controller
- Hanna® BL 982411 ORP Controller
- High Pressure Tank Switch
- Caster Wheels
- Wooden Shipping Crate



R2-6140
Reverse Osmosis System

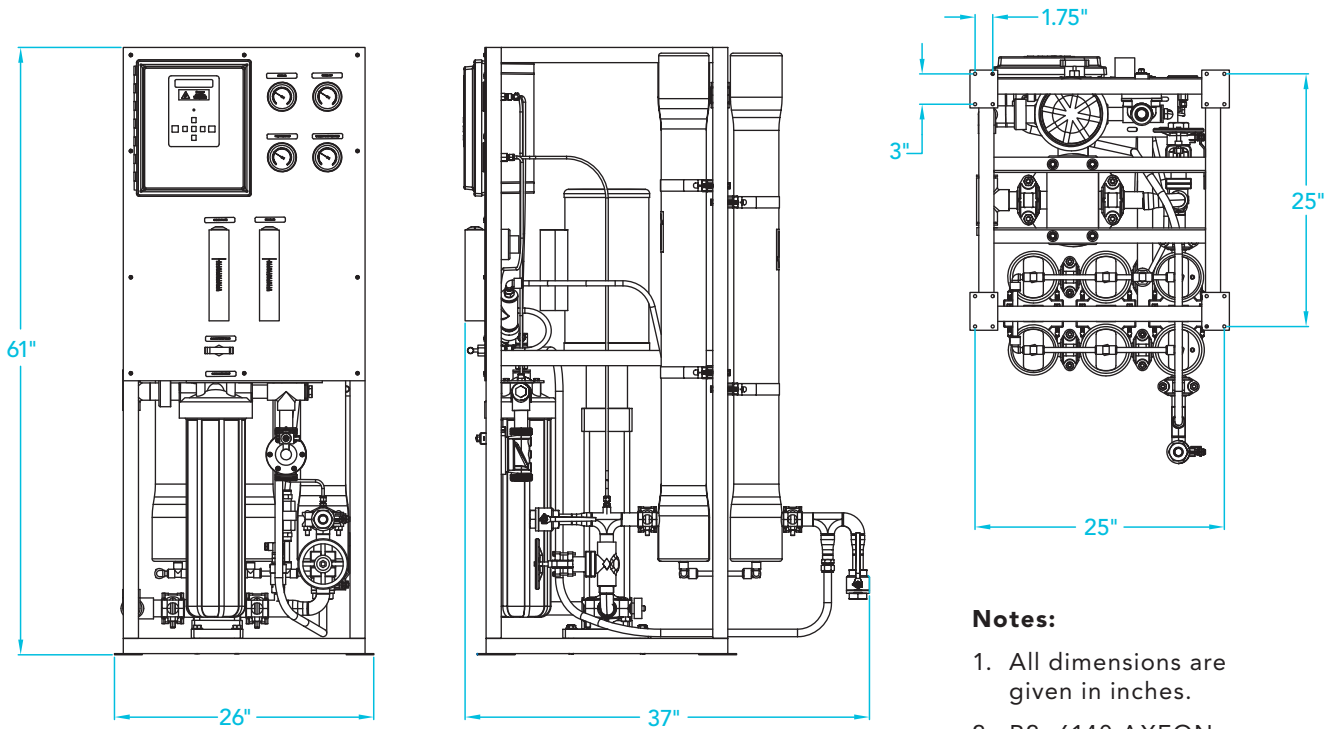

- Notes:**
1. All dimensions are given in inches.
 2. R2-6140 AXEON model shown.

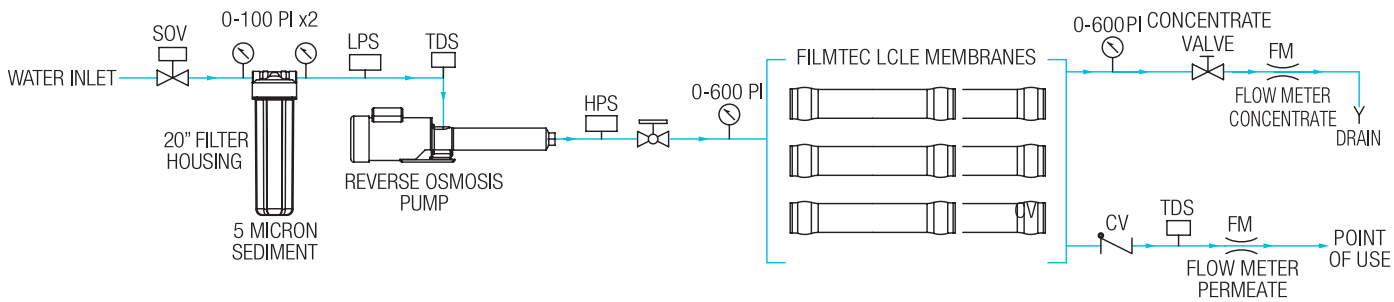

ARRAY SPECIFICATIONS

Model	Vessel Array	Vessel Size	Vessel Quantity	Membrane Size	Membrane Quantity
R2-1140	1	4040	1	4040	1
R2-2140	1:1	4040	2	4040	2
R2-3140	1:1:1	4040	3	4040	3
R2-4140	1:1:1:1	4040	4	4040	4
R2-5140	1:1:1:1:1	4040	5	4040	5
R2-6140	1:1:1:1:1:1	4040	6	4040	6

SPECIFICATIONS

MODELS	R2-1140	R2-2140	R2-3140	R2-4140	R2-5140	R2-6140
Design						
Configuration	Single Pass	Single Pass	Single Pass	Single Pass	Single Pass	Single Pass
Feedwater Source ^A	TDS < 10,000 ppm	TDS < 10,000 ppm	TDS < 10,000 ppm	TDS < 10,000 ppm	TDS < 10,000 ppm	TDS < 10,000 ppm
Standard Recovery Rate %	15-25	30-40	40-50	40-55	40-60	40-65
Rejection and Flow Rates^B						
Nominal Salt Rejection %	99.2	99.2	99.2	99.2	99.2	99.2
Permeate Flow (gpm / lpm)	1.04 / 3.94	2.08 / 7.89	3.13 / 11.83	4.17 / 15.77	5.21 / 19.72	6.25 / 23.66
Minimum Feed Flow (gpm / lpm)	4.04 / 15.30	5.08 / 19.20	6.13 / 23.20	7.17 / 27.10	8.21 / 31.10	9.25 / 35.00
Maximum Feed Flow (gpm / lpm)	14.00 / 53.00	14.00 / 53.00	14.00 / 53.00	14.00 / 53.00	14.00 / 53.00	14.00 / 53.00
Minimum Concentrate Flow (gpm / lpm)	3.00 / 11.36	3.00 / 11.36	3.00 / 11.36	3.00 / 11.36	3.00 / 11.36	3.00 / 11.36
Connections						
Feed (in)	1 FNPT	1 FNPT	1 FNPT	1 FNPT	1 FNPT	1 FNPT
Permeate (in)	3/4 FNPT	3/4 FNPT	3/4 FNPT	1 FNPT	1 FNPT	1 FNPT
Concentrate (in)	3/4 FNPT	3/4 FNPT	3/4 FNPT	1 FNPT	1 FNPT	1 FNPT
CIP (in)	3/4 FNPT	3/4 FNPT	3/4 FNPT	3/4 FNPT	3/4 FNPT	3/4 FNPT
Membranes						
Membrane Per Vessel	1	1	1	1	1	1
Membrane Quantity	1	2	3	4	5	6
Membrane Size	4040	4040	4040	4040	4040	4040
Vessels						
Vessel Array	1	1:1	1:1:1	1:1:1:1	1:1:1:1:1	1:1:1:1:1:1
Vessel Quantity	1	2	3	4	5	6
Pumps						
Pump Type	Multi-Stage	Multi-Stage	Multi-Stage	Multi-Stage	Multi-Stage	Multi-Stage
Motor HP	3	3	3	5	5	5
RPM @ 60 Hz (50 Hz)	3450 (2900)	3450 (2900)	3450 (2900)	3450 (2900)	3450 (2900)	3450 (2900)
System Electrical						
Standard Voltage + Amp Draw	220V, 60Hz, 1PH, 14.5A ^C	220V, 60Hz, 1PH, 14.5A ^C	220V, 60Hz, 1PH, 14.5A ^C	220V, 60Hz, 3PH, 14.2A ^C	220V, 60Hz, 3PH, 14.2A ^C	220V, 60Hz, 3PH, 14.2A ^C
High Voltage Service + Amp Draw	220V, 50Hz, 1PH, 17.4A ^C 220V, 50Hz, 3PH, 0.6A ^C 220V, 60Hz, 3PH, 9A ^C 460V, 60Hz, 3PH, 5A ^C	220V, 50Hz, 1PH, 17.4A ^C 220V, 50Hz, 3PH, 10.6A ^C 220V, 60Hz, 3PH, 9A ^C 460V, 60Hz, 3PH, 5A ^C	220V, 50Hz, 1PH, 17.4A ^C 220V, 50Hz, 3PH, 10.6A ^C 220V, 60Hz, 3PH, 9A ^C 460V, 60Hz, 3PH, 5A ^C	220V, 50Hz, 3PH, 16.1A ^C 460V, 60Hz, 3PH, 7A ^C	220V, 50Hz, 3PH, 16.1A ^C 460V, 60Hz, 3PH, 7A ^C	220V, 50Hz, 3PH, 16.1A ^C 460V, 60Hz, 3PH, 7A ^C
System Dimensions						
Approximate Dimensions ^D L x W x H (in/cm)	27 x 26 x 61 / 69 x 66 x 155	27 x 26 x 61 / 69 x 66 x 155	30 x 26 x 61 / 75 x 66 x 155	32 x 26 x 61 / 80 x 66 x 155	32 x 26 x 61 / 80 x 66 x 155	37 x 26 x 61 / 94 x 66 x 155
Approximate Weight (lbs / kg)	560 / 250	590 / 270	620 / 280	650 / 300	680 / 310	700 / 320

Test Parameters: 10,000 TDS Filtered (5-Micron), Dechlorinated, Municipal Feedwater, 65 psi / 4.50 bar Feed Pressure, 350 psi / 24.13 bar Operating Pressure, 77°F / 25°C, Recovery as stated, 7.0 pH. Data taken after 60 minutes of operation.

- A. Low temperatures and feedwater quality, such as high TDS levels will significantly affect the systems production capabilities and performance. Computer projections must be run for individual applications which do not meet or exceed minimum and maximum operating limits for such conditions.
- B. Product flow and maximum recovery rates are based on feedwater conditions as stated above. Do not exceed recommended permeate flow.
- C. Varies with motor manufacturer.
- D. Does not include operating space requirements.

OPERATING LIMITS^E

Maximum Feed Temperature (°F / °C)	85 / 29	Maximum Free Chlorine (ppm)	1
Minimum Feed Temperature (°F / °C)	40 / 4	Maximum TDS (ppm)	10,000
Maximum Ambient Temperature (°F / °C)	120 / 49	Maximum Hardness (gpg)	< 1
Minimum Ambient Temperature (°F / °C)	40 / 4	Maximum pH (continuous)	11
Maximum Feed Pressure (psi / bar)	85 / 6	Minimum pH (continuous)	2
Minimum Feed Pressure (psi / bar)	45 / 3	Maximum pH (cleaning 30 minutes)	13
Maximum Operating Pressure (psi / bar)	400 / 28	Minimum pH (cleaning 30 minutes)	1
Maximum Feed Silt Density Index (SDI)	< 3	Maximum Turbidity (NTU)	< 1

E. System pressure is variable due to water conditions. Permeate flow will increase at a higher temperature and will decrease at a lower temperature.

800-320-4074

AXEONwater.com

